

# FLIGHT MANUAL

## US-LSA



## P2004 Bravo

### Manufacturer

*COSTRUZIONI AERONAUTICHE TECNAM S.r.l.*

Type Certificate:     ASTM SLSA  
Serial number: \_\_\_\_\_  
Build year:         \_\_\_\_\_  
Registration: \_\_\_\_\_

This manual contains information to be furnished to the pilot as required by the FAA in addition to further information supplied by the manufacturer.

This manual must always be present on board the aircraft.

The aircraft is to be operated in compliance with information and limitations contained herein. All sections follow the ASTM guidelines as finalized 1 April 2005.

### 1.1.1 Record of Revisions

Any revisions to the present Manual, except actual weighing data, must be recorded in the following table. New or amended text in the revised pages will be indicated by a black vertical line in the left-hand margin; Revision No. and date will be shown on the left-hand side of the amended page.

### 1.1.2 Log of Revisions

Revision No.	Date released	Chapters	Approved By
1.0	03-30-2005	All	Tecnam
2.0	12-30-2006	All	Tecnam
2.01	01-22-2007	1	Tecnam
2.01a	02-26-2007	1	Tecnam
2.02	02-28-2007	6 (ALL)	Tecnam
2.03	05-09-2007	2, 8	Tecnam
2.03a	05-24-2007	6	Tecnam

**1.1.3 List of Valid Pages**

Page	Date	Page	Date	Page	Date
1	12-30-2006	36	12-30-2006	71	12-30-2006
2	12-30-2006	37	01-22-2007	72	12-30-2006
3	12-30-2006	38	01-22-2007	73	12-30-2006
4	12-30-2006	39	12-30-2006	74	12-30-2006
5	12-30-2006	40	12-30-2006	75	12-30-2006
6	12-30-2006	41	12-30-2006	76	12-30-2006
7	12-30-2006	42	12-30-2006	77	12-30-2006
8	12-30-2006	43	12-30-2006	78	12-30-2006
9	12-30-2006	44	12-30-2006		
10	12-30-2006	45	12-30-2006		
11	12-30-2006	46	12-30-2006		
12	12-30-2006	47	12-30-2006		
13	12-30-2006	48	12-30-2006		
14	12-30-2006	49	12-30-2006		
15	02-26-2007	50	12-30-2006		
16	02-26-2007	51	01-22-2007		
17	12-30-2006	52	12-30-2006		
18	12-30-2006	53	12-30-2006		
19	12-30-2006	54	12-30-2006		
20	12-30-2006	55	12-30-2006		
21	12-30-2006	56	12-30-2006		
22	02-26-2007	57	02-28-2007		
23	01-22-2007	58	05-24-2007		
24	12-30-2006	59	02-28-2007		
25	12-30-2006	60	02-28-2007		
26	02-26-2007	61	02-28-2007		
27	01-22-2007	62	02-28-2007		
28	01-22-2007	63	02-28-2007		
29	12-30-2006	64	12-30-2006		
30	05-09-2007	65	12-30-2006		
31	05-09-2007	66	05-09-2007		
32	12-30-2006	67	12-30-2006		
33	12-30-2006	68	12-30-2006		
34	12-30-2006	69	12-30-2006		
35	12-30-2006	70	12-30-2006		

## 1.2 Table of Contents

FLIGHT MANUAL .....	1
US-LSA .....	1
P2004 Bravo .....	1
1.1.1 Record of Revisions .....	2
1.1.2 Log of Revisions .....	2
1.1.3 List of Valid Pages .....	3
1.2 TABLE OF CONTENTS .....	4
1.2.1 WARNINGS - CAUTIONS - NOTES .....	8
1.3 ABBREVIATIONS & TERMINOLOGY .....	9
1.3.1 Airspeed Terminology .....	9
1.3.2 Meteorology Terminology .....	9
1.3.3 Engine Power Terminology .....	9
1.3.4 Airplane Performance and Flight Planning Terminology .....	10
1.3.5 Weight and Balance Terminology .....	10
1.3.6 Unit Conversion Chart .....	11
SECTION 1 GENERAL .....	12
1.4 INTRODUCTION .....	12
1.5 CERTIFICATION BASIS .....	12
1.6 DESCRIPTIVE DATA .....	14
1.6.1 Airframe .....	14
1.6.1.1 Wing .....	14
1.6.1.2 Fuselage .....	14
1.6.1.3 Empennage .....	14
1.6.1.4 Landing Gear .....	14
1.6.1.5 Flight Control Travel Limits .....	14
1.7 SYSTEMS .....	15
1.7.1 Engine .....	15
1.7.2 Propeller .....	15
1.7.3 Fuel .....	15
1.7.4 Oil System .....	15
1.7.5 Cooling .....	15
1.8 WEIGHTS .....	16
1.8.1 Maximum Weights .....	16
1.8.2 Standard Weights .....	16
1.8.3 Specific Loadings .....	16
1.9 STANDARD EQUIPMENT .....	16
1.9.1 Flight Instruments .....	16
1.9.2 Engine instruments .....	16
1.9.3 Warning Lights and Indicators .....	16
1.9.4 Controls .....	16
1.9.5 Interior .....	16
1.9.6 Exterior .....	16
1.9.7 Powerplant and Accessories .....	16
1.10 AIRFRAME .....	17
1.10.1 Wing .....	17
1.10.2 Fuselage .....	17
1.10.3 Empennage .....	17
1.10.4 Flight Controls .....	17
1.10.5 Instrument Panel .....	18
1.10.6 Carburetor Heat (optional) .....	18
1.10.7 Cabin Heat .....	18
1.10.8 Throttle Friction Lock .....	18

1.10.9	Seats, Seatbelts, and Shoulder Harnesses .....	18
1.10.10	Doors .....	19
1.10.11	Baggage Compartment .....	19
1.11	POWERPLANT .....	19
1.11.1	Engine.....	19
1.11.2	Propeller .....	19
1.11.3	Fuel System .....	19
1.12	ELECTRICAL SYSTEM .....	21
1.12.1	Generator light.....	21
1.12.2	Voltmeter .....	21
1.12.3	Oil temperature gauge .....	21
1.12.4	Cylinder head temperature.....	21
1.12.5	Oil Pressure .....	22
1.12.6	Fuel Pressure .....	22
1.12.7	O.A.T. Indicator (optional).....	22
1.12.8	Stall Warning System (optional) .....	22
1.12.9	Avionics (optional).....	22
1.12.10	Exterior Lighting .....	22
1.12.10.1	Navigation Lights (Optional).....	22
1.12.10.2	Landing Light .....	22
1.12.10.3	Tail Strobe Light.....	22
1.13	PITOT AND STATIC PRESSURE SYSTEMS .....	23
1.14	LANDING GEAR.....	24
1.14.1	Brake System.....	24
<b>SECTION 2 OPERATING LIMITATIONS .....</b>		<b>26</b>
2	Introduction .....	26
2.1.1	Airspeed Limitations .....	26
2.1.2	Airspeed Indicator Markings .....	26
2.1.3	Powerplant Limitations .....	27
2.1.4	Temperatures .....	27
2.1.5	Oil Pressure .....	27
2.1.6	Operating & starting temperature range .....	27
2.1.7	Fuel Pressure .....	27
2.1.8	Lubricant .....	28
2.1.8.1	Viscosity .....	28
2.1.9	Coolant .....	28
2.1.10	Propeller .....	28
2.1.11	Fuel.....	28
2.1.12	Approved Fuel.....	29
2.1.13	Powerplant Instrument Markings .....	29
2.1.14	Other Instrument Markings .....	29
2.1.15	Weights.....	29
2.1.16	Center of Gravity Range.....	29
2.1.17	Approved Maneuvers .....	30
2.1.18	Maneuvering Load Factor Limits .....	30
2.1.18.1	Flight Crew .....	30
2.1.18.2	Maximum passenger seating.....	30
2.1.19	Kinds of Operation .....	30
2.1.20	Demonstrated Crosswind Safe Operations .....	31
2.1.21	Service Ceiling .....	31
2.1.22	Limitation Placards.....	31
2.1.23	Night.....	31
2.1.24	IFR.....	31
<b>SECTION 3 WEIGHT &amp; BALANCE .....</b>		<b>32</b>

3	Introduction .....	32
3.1	AIRCRAFT WEIGHING PROCEDURES .....	32
3.1.1	Preparation.....	32
3.1.2	Leveling.....	32
3.1.3	Weighing .....	32
3.1.4	Determination of C.G. location .....	32
3.1.5	Weighing Report .....	34
3.1.6	Center of Gravity Range.....	34
3.1.7	Distances from the datum.....	35
3.2	WEIGHT AND BALANCE .....	36
3.2.1	Loading.....	37
3.3	EQUIPMENT LIST.....	38
<b>SECTION 4 PERFORMANCE.....</b>		<b>41</b>
4	Introduction .....	41
4.1	USE OF PERFORMANCE CHARTS.....	41
4.1.1	Conversion Charts .....	42
4.1.1.1	Kilogram to pound conversion chart.....	42
4.1.1.2	Meters to Feet .....	42
4.1.1.3	Kilometers to Knots.....	42
4.1.2	Airspeed Indicator System Calibration.....	43
4.1.3	ICAO Chart .....	44
4.1.4	Stall Speed.....	45
4.1.5	Crosswind.....	46
4.1.6	Takeoff performance .....	47
4.1.7	Climb Performance.....	48
4.2	CRUISE.....	49
4.2.1	Landing Distance.....	50
4.3	EFFECTS OF RAIN AND INSECTS .....	50
4.4	NOISE DATA.....	50
<b>SECTION 5 EMERGENCY PROCEDURES .....</b>		<b>51</b>
5	Introduction .....	51
5.1	ENGINE FAILURES .....	52
5.1.1	Engine Failures on Ground.....	52
5.1.1.1	ENGINE FAILURE DURING TAKEOFF RUN .....	52
5.1.2	Engine Failure during Flight.....	52
5.1.2.1	ENGINE FAILURE IMMEDIATELY AFTER TAKEOFF .....	52
5.1.2.2	IRREGULAR ENGINE RPM .....	52
5.1.2.3	LOW FUEL PRESSURE.....	52
5.1.2.4	LOW OIL PRESSURE.....	53
5.1.2.5	IN-FLIGHT ENGINE RESTART .....	53
5.1.2.6	ENGINE OUT GLIDE .....	53
5.2	SMOKE AND FIRE .....	53
5.2.1	Engine Fire while parked.....	53
5.2.2	Engine Fire during Takeoff .....	53
5.2.3	Engine Fire in-flight .....	54
5.2.4	Cabin Fire during Flight .....	54
5.3	LANDING EMERGENCY .....	54
5.3.1.1	FORCED LANDING WITHOUT ENGINE POWER .....	54
5.3.1.2	POWER-ON FORCED LANDING .....	54
5.3.1.3	LANDING WITH A FLAT NOSE TIRE.....	54
5.3.1.4	LANDING WITH A FLAT MAIN TIRE.....	55
5.4	RECOVERY FROM UNINTENTIONAL SPIN .....	55
5.5	OTHER EMERGENCIES .....	55
5.5.1	Unintentional Flight Into Icing Conditions.....	55

5.5.2	Carburetor Ice .....	55
5.5.2.1	AT TAKEOFF .....	55
5.5.2.2	IN FLIGHT .....	55
5.6	ELECTRIC POWER SYSTEM MALFUNCTION .....	55
5.6.1	GENERATOR LIGHT ILLUMINATES .....	56
5.7	TRIM SYSTEM FAILURE .....	56
5.7.1	LOCKED CONTROL .....	56
<b>SECTION 6 NORMAL PROCEDURES .....</b>		<b>57</b>
6	Introduction .....	57
6.1	REMOVING AND REINSTALLING THE ENGINE COWLING .....	57
6.1.1	Upper Cowling .....	57
6.1.2	Lower Cowling .....	57
6.2	CHECKLIST PROCEDURES .....	58
6.2.1	Pre-Flight Inspection .....	58
6.2.1.1	Cabin Inspection .....	58
6.2.1.2	External Inspection .....	59
6.2.1.3	BEFORE START .....	60
6.2.1.4	STARTING ENGINE .....	60
6.2.1.5	BEFORE TAXI .....	61
6.2.1.6	TAXI .....	61
6.2.1.7	BEFORE TAKE-OFF .....	61
6.2.1.8	TAKEOFF AND CLIMB .....	61
6.2.1.9	CRUISE .....	62
6.2.1.10	BEFORE LANDING .....	62
6.2.1.11	BALKED LANDING .....	62
6.2.1.12	AFTER LANDING .....	62
6.2.1.13	ENGINE SHUT DOWN .....	63
6.2.1.14	POSTFLIGHT CHECK .....	63
<b>SECTION 7 GROUND HANDLING &amp; SERVICE .....</b>		<b>64</b>
7	Introduction .....	64
7.1	AIRCRAFT INSPECTION PERIODS .....	64
7.2	AIRCRAFT ALTERATIONS OR REPAIRS .....	64
7.3	GROUND HANDLING .....	64
7.3.1	Towing .....	64
7.3.2	Parking and Tie down .....	64
7.3.3	Jacking .....	64
7.3.4	Leveling .....	64
7.3.5	Road Transport .....	64
7.3.6	Cleaning and Care .....	65
<b>Section 8 REQUIRED PLACARDS &amp; MARKINGS .....</b>		<b>66</b>
8	Required Placards and Markings .....	66
<b>Section 9 FLIGHT TRAINING SUPPLEMENT .....</b>		<b>67</b>
9	Introduction .....	67
9.1.1	TECNAM History .....	67
9.1.2	Understanding ASTM Requirements .....	67
9.1.3	Aircraft Limitations .....	67
9.2	PREFLIGHT PLANNING .....	69
9.2.1	Checklists .....	69
9.2.2	IM SAFE .....	70
9.2.3	Preflight Inspection .....	70
9.2.4	Cabin Inspection .....	70
9.2.5	External Inspection .....	70
9.2.6	Before Start .....	70
9.2.7	Engine Start .....	70

9.2.8	Before Taxiing.....	71
9.2.9	Taxiing.....	71
9.2.10	Before Takeoff Checks.....	71
9.2.11	Takeoff and Climb.....	71
9.2.12	Cruise .....	71
9.2.13	Descent .....	71
9.2.14	Before Landing.....	72
9.2.15	Balked Landing .....	72
9.2.16	Landing.....	72
9.2.17	After Landing .....	72
9.2.18	Engine Shutdown and Securing.....	72
9.2.19	Post Flight Check .....	72
9.3	FLIGHT MANEUVERS.....	73
9.3.1	Straight and Level Flight .....	73
9.3.2	Turns.....	73
9.3.3	Climbs .....	73
9.3.4	Descents.....	74
9.3.5	Stalls .....	75
9.3.6	Slow Flight .....	75
9.3.7	Flight at minimum controllable airspeed.....	76
9.4	PERFORMANCE MANEUVER .....	77
9.4.1	Steep Turns.....	77
9.5	EMERGENCY PROCEDURES.....	77

### 1.2.1 WARNINGS - CAUTIONS - NOTES

The following definitions apply to warnings, cautions and notes used in the Flight Manual.

#### WARNING

Means that the non-observation of the corresponding procedure leads to an immediate or important degradation of the flight safety

#### CAUTION

Means that the non-observation of the corresponding procedure leads to a minor or to a more or less long-term degradation of the flight safety

#### NOTE

Draws the attention to any special item not directly related to safety but which is important or unusual.

## 1.3 Abbreviations & Terminology

### 1.3.1 Airspeed Terminology

KCAS	Calibrated Airspeed is the indicated airspeed corrected for position and instrument error and expressed in knots.
KIAS	Indicated Airspeed is the speed shown on the airspeed indicator and expressed in knots.
KTAS	True Airspeed is the airspeed expressed in knots relative to undisturbed air, which is KCAS, corrected for altitude and temperature.
V <sub>A</sub>	Design maneuvering speed
V <sub>C</sub>	Design cruising speed
V <sub>FE</sub>	Maximum Flap Extended Speed is the highest speed permissible with wing flaps in a prescribed extended position.
V <sub>H</sub>	Max Speed in level flight with Max continuous power
V <sub>LO</sub>	Lift off speed: is the speed at which the aircraft generally lifts off from the ground.
V <sub>NE</sub>	Never Exceed Speed is the speed limit that may not be exceeded at any time.
V <sub>NO</sub>	Maximum Structural Cruising Speed is the speed that should not be exceeded except in smooth air, then only with caution.
V <sub>S</sub>	Stalling Speed or minimum steady flight speed flaps retracted
V <sub>S0</sub>	Stalling speed or minimum steady flight speed in landing configuration
V <sub>S1</sub>	Stalling speed in clean configuration (flap 0°)
V <sub>X</sub>	Best Angle-of-Climb Speed is the speed, which results in the greatest gain of altitude in a given horizontal distance.
V <sub>Y</sub>	Best Rate-of-Climb Speed is the speed, which results in the greatest gain in altitude in a given time.
V <sub>R</sub>	Rotation speed: is the speed at which the aircraft rotates about the pitch axis during takeoff.

### 1.3.2 Meteorology Terminology

OAT	Outside Air Temperature is the free air static temperature expressed in degrees Celsius (°C).
T <sub>S</sub>	Standard Temperature is 15°C (59°F) at sea level pressure altitude and decreased by 2°C for each 1000 ft of altitude.
H <sub>P</sub>	Pressure Altitude is the altitude read from an altimeter when the barometric subscale has been set to 29.92"

### 1.3.3 Engine Power Terminology

RPM	Revolutions Per Minute: is the number of revolutions per minute of the propeller, multiplied by 2.4286 yields engine RPM.
-----	---------------------------------------------------------------------------------------------------------------------------

### 1.3.4 Airplane Performance and Flight Planning Terminology

Crosswind Velocity	is the velocity of the crosswind component for which adequate control of the airplane during takeoff and landing is guaranteed
Usable fuel	is the fuel available for flight planning
Unusable fuel	is the quantity of fuel that cannot be safely used in flight
g	is the acceleration of gravity
TOR	is the takeoff distance measured from actual start to wheel lift off point
TOD	is total takeoff distance measured from start to clearing a 50' obstacle
GR	is the distance measured during landing from actual touchdown to stop point
LD	is the distance measured during landing, from clearing a 50' obstacle to actual stop
S/R	is specific range, that is, the distance (in nautical miles) which can be expected at a specific power setting and/or flight configuration per gallon of fuel used

### 1.3.5 Weight and Balance Terminology

Datum	“Reference datum” is an imaginary vertical plane from which all horizontal distances are measured for balance purposes
Arm	is the horizontal distance from the reference datum to the center of gravity (C.G.) of an item
Moment	is the product of the weight of an item multiplied by its arm
C.G.	Center of Gravity is the point at which the airplane, or equipment, would balance if suspended. Its distance from the reference datum is found by dividing the total moment by the total weight of the airplane
Empty Weight	Empty Weight is the weight of the airplane with engine fluids and oil at operating levels
Useful Load	is the difference between takeoff weight and the empty weight
Maximum Takeoff Weight	is the maximum weight approved for the start of the takeoff run
Maximum Landing Weight	is the maximum weight approved for the landing touch down
Tare	is the weight of chocks, blocks, stands, etc. used when weighing an airplane, and is included in the scale readings; tare is then deducted from the scale reading to obtain the actual (net) airplane weight

**1.3.6 Unit Conversion Chart**

Multiplying		by →	yields	
<b>Temperature</b>				
Fahrenheit	[°F]	$\frac{5}{9} \cdot (F - 32)$	Celsius	[°C]
Celsius	[°C]	$(\frac{9}{5} \cdot C) + 32$	Fahrenheit	[°F]
<b>Forces</b>				
Kilograms	[kg]	2.205	Pounds	[lbs]
Pounds	[lbs]	0.4536	Kilograms	[kg]
<b>Speed</b>				
Meters per second	[m/s]	196.86	Feet per minute	[ft/min]
Feet per minute	[ft/min]	0.00508	Meters per second.	[m/s]
Knots	[kts]	1.853	Kilometers / hour	[km/h]
Kilometers / hour	[km/h]	0.5396	Knots	[kts]
<b>Pressure</b>				
Atmosphere	[atm]	14.7	Pounds / sq. in	[psi]
Pounds / sq. in	[psi]	0.068	Atmosphere	[atm]
<b>Length</b>				
Kilometers	[km]	0.5396	Nautical miles	[nm]
Nautical miles	[nm]	1.853	Kilometers	[km]
Meters	[m]	3.281	Feet	[ft]
Feet	[ft]	0.3048	Meters	[m]
Centimeters	[cm]	0.3937	Inches	[in]
Inches	[in]	2.540	Centimeters	[cm]
<b>Volume</b>				
Liters	[l]	0.2642	U.S. Gallons	[US Gal]
U.S. Gallons	[US Gal]	3.785	Liters	[l]
<b>Area</b>				
Square meters	[m <sup>2</sup> ]	10.76	Square feet	[sq ft]
Square feet	[sq ft]	0.0929	Square meters	[m <sup>2</sup> ]
<b>Torque</b>				
foot-pounds		1.3558	Newton-meters	
foot-pounds		0.1383	kilogram-meters	
foot-pounds		12.0	inch-pounds	
inch-pounds		0.0115	kilogram-meters	
inch-pounds		0.1130	Newton-meters	
inch-pounds		0.0833	foot-pounds	
kilogram-meters		7.233	foot-pounds	
kilogram-meters		86.7964	inch-pounds	
kilogram-meters		9.8067	Newton-meters	
Newton-meters		0.7376	foot-pounds	
Newton-meters		8.8508	inch-pounds	
Newton-meters		0.1020	kilogram-meter	

## SECTION 1 GENERAL

### 1.4 Introduction

The P2004 Bravo is a cantilevered high wing, side by side seat airplane, powered by a Rotax 912 73 kW (100hp) engine. The Bravo features a tapered cantilevered wing. Laminar airfoils, large slotted flaps with up-turned wing tips, and a streamlined fuselage, leads to a high performance airplane with increased cruise speed and range.

The P2004 Bravo is the result of Tecnam's continuous improvement arising from the experiences of a varied and extended use over time of hundreds of planes all over the world. Furthermore, the continuous research and development in the aerodynamics, structures, and systems, has been the key to our success. The plane's outstanding performance and flying qualities together with low operating costs, easy piloting and maintenance, make this aircraft an excellent solution for flight-schools, training activity, and also for many other missions.

This Flight Manual has been prepared to provide pilots and instructors with information for the safe and efficient operation of this aircraft.

This Flight Manual contains the following sections:

- General Information
- Operating Limitations
- Weight & Balance
- Performance
- Emergency Procedures
- Normal Procedures
- Aircraft Ground Handling and Servicing
- Required Placards and Markings
- Supplementary Information

### 1.5 Certification Basis

This aircraft complies with ASTM standards and is certificated as a Special Light Sport Aircraft.

THREE-VIEW DRAWING

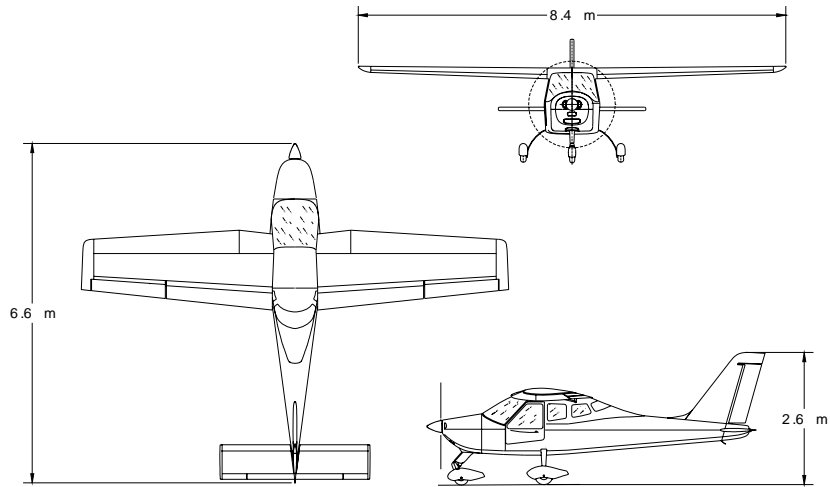

Figure 1-1 General Views

Wing Span:	8.4m (27.55')
Length:	6.6m (21.65')
Tail height:	2.6m (8.5')
Minimum ground steering radius	5.5 m (18')
Propeller ground clearance	320 mm (12.6")

**NOTE**

- Dimensions shown refer to aircraft weight of 600 kg (1320 lbs) and normal operating tire pressure
- Propeller ground clearance with deflated front tire and nosewheel shock absorber compressed by 102mm (4")

## 1.6 Descriptive Data

### 1.6.1 Airframe

#### 1.6.1.1 Wing

Wing span:	8.4 m (27.55')
Wing surface	11 m <sup>2</sup> (118 <sup>2</sup> )
Wing loading	41 kg/m <sup>2</sup> (11.18 lb/ft <sup>2</sup> )
Aspect ratio	6.5
Taper ratio	0.6
Dihedral	1.5°

#### 1.6.1.2 Fuselage

Overall length	6.6 m (21.65')
Overall width	1.1 m (3.6')
Overall height	2.6 m (8.5')

#### 1.6.1.3 Empennage

Stabilator span	2.9 m (9.5')
Vertical tail span	1.4 m (4.6')

#### 1.6.1.4 Landing Gear

Wheel track:	1.8 m (6')
Wheel base:	1.6 m (5.2')
Main gear tires: Air Trac	(5.00-5)
Nose gear tire: Sava	(4.00-6)

#### 1.6.1.5 Flight Control Travel Limits

Ailerons	Up 20° down 15° ± 2°
Stabilator	Up 15° down 3° ± 1°
Trim-Tab	2° ; 9° ± 1°
Rudder	RH 30° LH 30° ± 2°
Flaps	0°; 39° ± 2°

## 1.7 Systems

### 1.7.1 Engine

Manufacturer:	Bombardier-Rotax GmbH
Model	912 ULS or 912 S2 (optional)
Certification basis	ASTM F2239-05 or FAR 33
Austrian T.C. No.	TW 9-ACG dated 27th November 1998
Type:	4 cylinder horizontally opposed twins with overall displacement of 1352 c.c. mixed cooling, (water-cooled heads and air-cooled cylinders), twin carburetors, integrated reduction gear with torque damper.
Maximum rating:	73.5kW (98.6hp) @ 5800 rpm (max 5 minutes) 69.0 kW (92.5 hp) @ 5500rpm (max continuous)
Gear reduction ratio	2.4286:1
Max oil consumption	Max: 0.1 liters/hour

### 1.7.2 Propeller

Manufacturer:	F.lli Tonini Giancarlo & Felice S.n.c.
Model:	GT-2/173/VRR- FW101 SRTC
Number of blades:	2
Diameter:	1730 mm (68") (no reduction permitted)
Type:	Fixed pitch – wood

### 1.7.3 Fuel

Fuel grade:	Min. RON 95 Auto Fuel (AKI 91 Premium USA) AVGAS 100LL
Fuel tanks:	2 wing tanks integrated within the wing's leading edge with a fuel strainer located in engine cowling
Capacity of each wing tank	50 liters (13.2 gal)
Total capacity:	100 liters (26.4 gal)
Total usable fuel	99 liters (26.15 gal)

### 1.7.4 Oil System

Oil system:	Forced, with external oil reservoir
Oil:	See Rotax operator's manual
Oil Capacity:	Max. 3.0 liters (3.2 qt) – min. 2.0 liters (2.1 qt)

### 1.7.5 Cooling

Cooling system:	Mixed air and liquid pressurized closed circuit system
Coolant:	See Rotax operator's manual

## 1.8 Weights

### 1.8.1 Maximum Weights

Maximum take-off weight:	600 kg (1320 lbs)
Maximum landing weight:	600 kg (1320 lbs)
Maximum baggage weight	20 kg (44 lbs)

### 1.8.2 Standard Weights

Standard Empty Weight	281 kg (620 lbs)
Maximum useful load	319 kg (700 lbs)

### 1.8.3 Specific Loadings

Wing Loading	54.54 kg/m <sup>2</sup> (11.186 lbs/ft <sup>2</sup> )
Power Loading	4.6 kg/hp (10.1 lbs/hp)

## 1.9 Standard Equipment

<b>1.9.1 Flight Instruments</b>
Airspeed Indicator, Altimeter, Vertical Speed Indicator, Compass
<b>1.9.2 Engine instruments</b>
Tachometer, Oil Pressure, Fuel Pressure, Oil Temperature, Cylinder Head Temperature, Hour Meter, Left and Right Fuel Quantity, Volt Meter
<b>1.9.3 Warning Lights and Indicators</b>
Trim Indicator, Flap Indicator, Generator Warning Light
<b>1.9.4 Controls</b>
Dual Stick Flight Controls, Rudder Pedals, Dual Throttles, Throttle Friction Control, Engine Choke, Electric Flaps, Hydraulic Disc Brakes, Parking Brake, Left and Right Fuel Selector Valves, Direct Nose Wheel Steering
<b>1.9.5 Interior</b>
Adjustable Pilot and Copilot Seats, Acoustic Cabin Soundproofing, Adjustable Cabin Air Ventilators, Steel Roll Cage, Cabin Heat, Windshield Defrost, 12V Power Outlet, Metal Instrument Panel
<b>1.9.6 Exterior</b>
All Aluminum structure, Landing Light, Tail Strobe Light, Fixed Landing Gear, Nose Gear Strut Fairing, Nose and Main Wheel Fairings
<b>1.9.7 Powerplant and Accessories</b>
Rotax 912 ULS Engine (100 hp), Composite Covered Wood Propeller with Spinner, 12Volt 18 Ah Battery, 18 Amp Alternator, Engine Driven Fuel Pump, Electric Aux Fuel Pump, Electric Starter, Engine Exhaust Muffler, Gascolator with Quick Drain, Integral Wing Fuel Tanks, All Electric Circuits Fuse Protected

## 1.10 Airframe

### 1.10.1 Wing

The wing is constructed of a central light alloy torque box; an aluminum leading edge with integrated fuel tank is attached to the front spar while flap and aileron are hinged to rear spar. Flaps and ailerons are constructed of a center spar to which front and rear ribs are joined; wrap-around aluminum skin panels cover the structure.

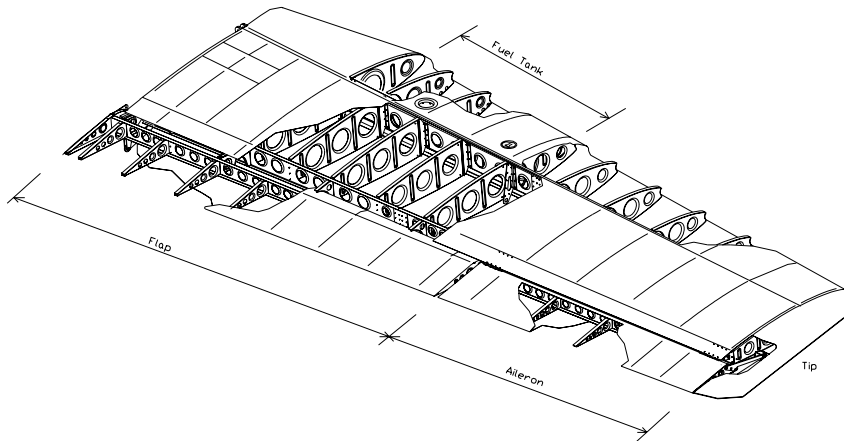

Fig. 1-1 Right wing exploded view

### 1.10.2 Fuselage

The front part of the fuselage is made up of a mixed structure: a truss structure with special steel members for cabin survival cell, and a light-alloy semi-monocoque structure for the cabin's bottom section. The aft part of the fuselage is constructed of an aluminum alloy semi-monocoque structure. The engine housing is isolated from the cabin by a firewall; the steel stringers engine mount is attached to the cabin's truss structure in four points.

### 1.10.3 Empennage

The vertical tail is entirely metal. The vertical fin is made up of a twin spar with stressed skin while the rudder consists of an aluminum torque box made of light alloy ribs and skin. The horizontal tail is an all-moving type (stabilator); its structure consists of an aluminum spar connected to ribs and leading edge covered by an aluminum skin.

### 1.10.4 Flight Controls

Aircraft flight controls are operated through conventional stick and rudder pedals. Longitudinal control acts through a system of push-rods and is equipped with a trim tab. Aileron control is of mixed type with push-rods and cables; the cable control circuit is confined within the cabin and is connected to a pair of push-rods positioned in the wings that control ailerons differentially. Aileron trimming is carried out on ground through a small tab positioned on left aileron. Flaps are extended via an electric servo actuator controlled by a switch on the control stick. Flaps act in a continuous mode; the indicator displays the two positions relative to takeoff (15°) and landing (40°). A fuse positioned on the right side of the instrument panel protects the electric circuit.

Longitudinal trim is performed by a small tab positioned on the stabilator and controlled via an electric servo operated by pushing the Up/Down buttons on the control stick, for this installation a shunt switch placed on the instrument panel enables control of either the left or the right stick.



### 1.10.10 Doors

Standard doors feature a light alloy tubular frame supporting a clear or tinted window. An internal safety latch mechanism is positioned in proximity of the door's upper edge and must be used before flight to secure the door. Rotate the latch before flight to lock doorframe to cabin tubular framework.

### 1.10.11 Baggage Compartment

The baggage compartment is located behind the seats. Baggage should be evenly distributed and weight shall not exceed 20 kg (44 pounds). Tie down baggage by using adjustable tie-down net.

## 1.11 Powerplant

### 1.11.1 Engine

Rotax is an Austrian engine manufacturer, founded in 1920 in Dresden, Germany. In 1970 Rotax was bought by Bombardier. The company constructed only two-stroke engines until 1982, when it started building four-stroke engines. In 1989, Rotax received Type Certification for its 912 A aircraft engine.

The Rotax 912 ULS engine is an ASTM compliant engine. The 912 is a four stroke, horizontally opposed, spark ignition engine with single central camshaft with hydraulic tappets. The 912 has liquid cooled cylinder heads and ram air cooled cylinders and engine. It is rated at 5800 RPM and can be run continuously at 5500 RPM.

The oil system is a dry sump, forced lubrications system. The oil tank is located on the passenger side of the engine compartment and holds 3 liters (3.2 quarts) of oil.

The dual ignition system is a solid state, breakerless, capacitive discharge, interference suppression system instead of a mechanical magneto system. Each ignition system is powered by individual and totally independent AC generators which are not dependent on the aircraft battery.

The electrical system consists of an integrated AC generator with an external rectifier – regulator. An optional external alternator can be installed. The Rotax engine is equipped with an electric starter.

The dual carburetors are constant depression carburetors that automatically adjust for altitude.

The fuel system is equipped with an engine driven mechanical pump and a back up electric pump.

The cooling system is a mixture of liquid and air cooling.

The engine uses a reduction gearbox with a gear reduction ratio of 2.4286:1.

The engine is controlled by two throttles in the cockpit. The throttles are bussed together and will not move independently.

The two throttles are installed to allow the pilot to fly with either hand as well as giving the pilot the option of using the left hand throttle while operating the center mounted brake handle.

The owner can register and get important information from the following website: <http://www.rotax-owner.com/>.

### 1.11.2 Propeller

The GT propeller is a wood composite propeller. It is built by GT Eliche del f.lli Tonini in Riccione, Italy.

The propeller is finished with a white polyurethane lacquer and an additional layer of transparent lacquer. The tips are painted in bright yellow and red so that when the propeller is turning it is obvious to personnel on the ground. The back of the propeller is painted black to prevent reflections.

### 1.11.3 Fuel System

The system is equipped with two aluminum fuel tanks integrated within the wing leading edge and accessible for inspection through dedicated covers. Capacity of each individual tank is 50 liters (13.2 gallons) and the total fuel capacity is 100 liters (26.4 gallons). Each fuel tank is equipped with a cabin installed shutoff valve. A Gascolator with a drain valve is located on the engine side of the firewall on the passenger side of the airplane. Fuel level gauges for each tank are located on the instrument panel. Fuel feed is through an engine-driven mechanical pump and through an electric pump (normally ON for takeoff and landing) that supplies adequate engine feed in case of main pump failure. Figure 1-3 illustrates the schematic layout of the fuel system.

#### WARNING

Fuel quantity should be checked on a level surface or a false reading may result. Always visually verify fuel quantity by looking in the tanks.

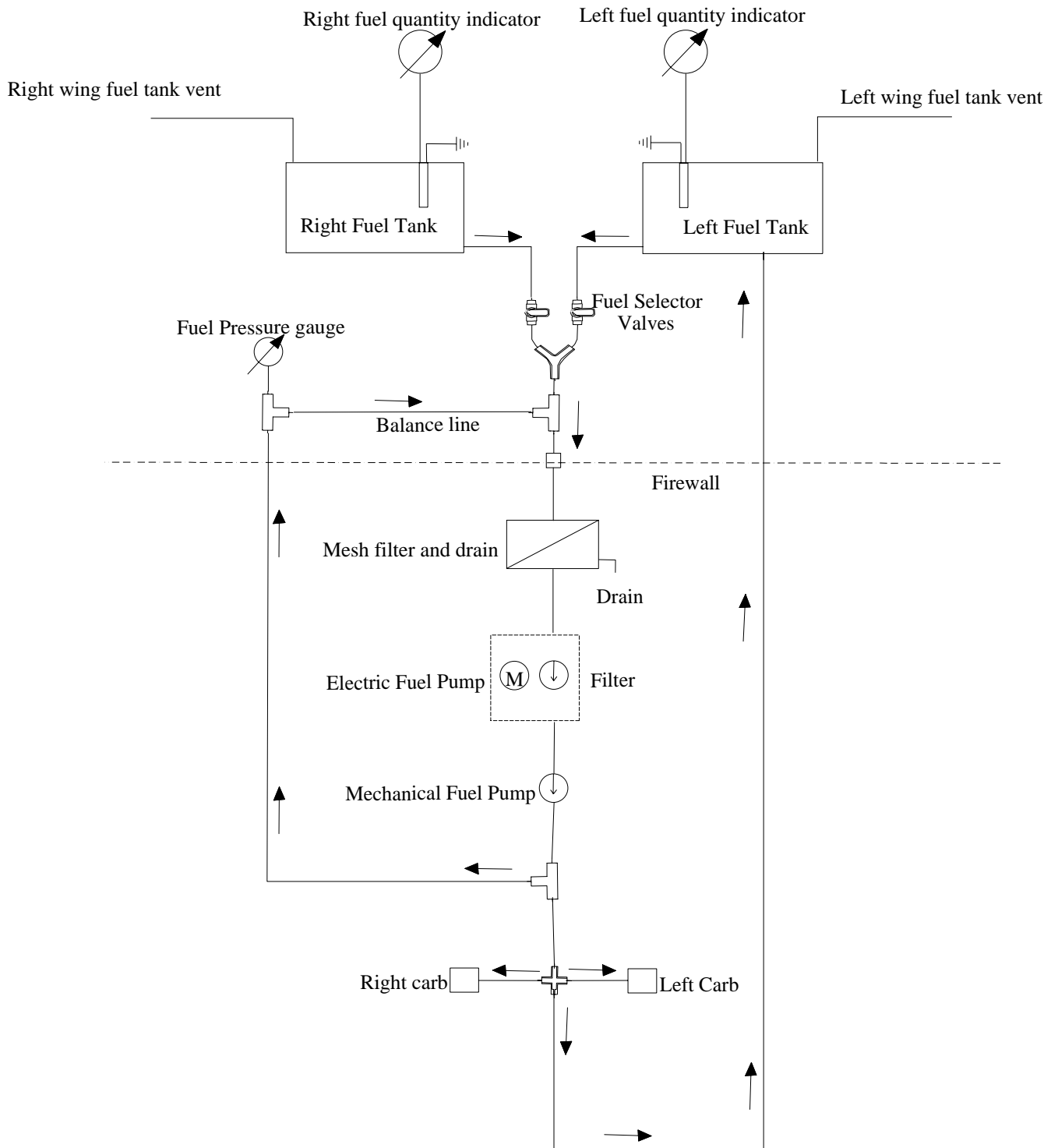

Fig.1-3. Fuel system schematic

## 1.12 Electrical System

The aircraft's electrical system consists of a 12 Volt DC circuit controlled by a Master switch located on the instrument panel. Electricity is provided by an integrated AC generator and a 12 Volt battery placed in the fuselage or in the engine compartment. The generator light is located on the right side of the instrument panel.

### WARNING

If the Ignition Switches are ON, an accidental movement of the propeller may start the engine with possible danger for bystanders.

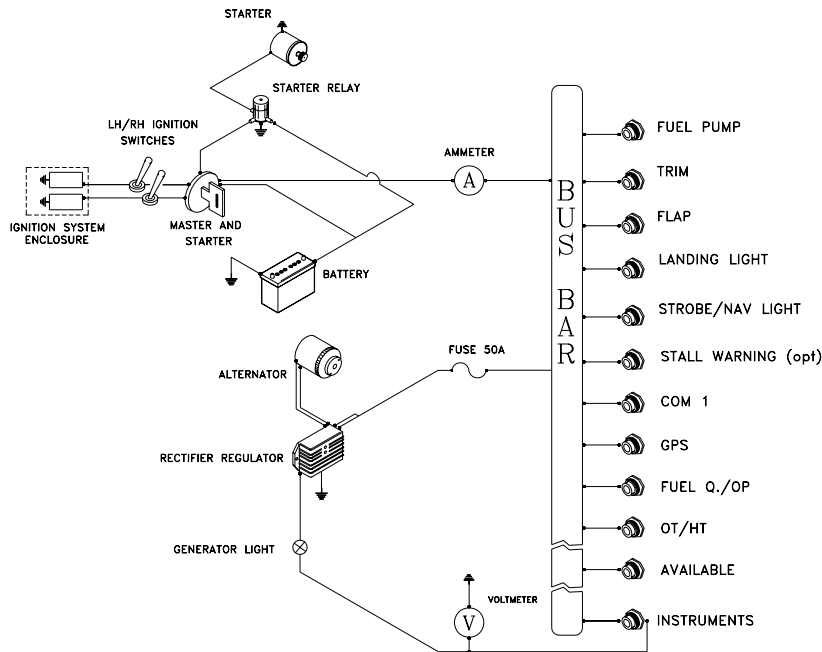

Fig.1-4. Electrical system schematic

### 1.12.1 Generator light

Generator light (red) illuminates for the following conditions:

- Generator failure
- Failure of the regulator/rectifier, with consequent over voltage sensor set to off.

A fully charged battery can support energy requirements for approximately 20 minutes.

### 1.12.2 Voltmeter

The voltmeter indicates voltage on the bus bar. The normal range is from 12 to 14 volts. There is a red radial line at 10 volts.

### 1.12.3 Oil temperature gauge

Temperature reads in degrees Celsius. The oil temperature gauge has a green normal operating range, yellow caution ranges, and two red lines.

### 1.12.4 Cylinder head temperature

The cylinder head temperature gauge normally reads the number three cylinder head temperature. It also indirectly reflects the coolant temperature. The cylinder head temperature reads in degrees Celsius.

**NOTE**

The same fuse protects all temperature instruments.

**1.12.5 Oil Pressure**

The oil pressure gauge is electric and is protected by a fuse. It reads in bars and has a green normal operating range, yellow caution ranges, and two red lines.

**1.12.6 Fuel Pressure**

Fuel pressure is calibrated in bars. It is directly connected to the fuel system and is not electric.

**NOTE**

One bar is equal to about 14.7 pounds of pressure

**1.12.7 O.A.T. Indicator (optional)**

A digital Outside Air Temperature indicator (°C) is located on the upper left side of the instrument panel. The sensor is placed on cabin top.

**1.12.8 Stall Warning System (optional)**

The aircraft may be equipped with a stall warning system consisting of a sensor located on the right wing leading edge connected to a warning horn located on the instrument panel.

**1.12.9 Avionics (optional)**

The central part of the instrument panel holds room for avionics equipment. The manufacturer of each individual system furnishes features for each system.

**1.12.10 Exterior Lighting**

Typical exterior lighting consists of:

- Navigation lights (optional)
- Landing light
- Tail Strobe Light
- Wing Strobe Lights (optional)

**1.12.10.1 Navigation Lights (Optional)**

Navigation lights are installed on the wing tips and on top of vertical stabilizer. All navigation lights are controlled by a single switch located on instrument panel. The lights are protected by a fuse.

A green light is located on right wing tip, a red light on left wing tip and a white lamp is on vertical stabilizer.

**1.12.10.2 Landing Light**

The landing light is located on the LH wing leading edge. Landing light switch is located on instrument panel. Light is protected by a 10 Amp fuse.

**1.12.10.3 Tail Strobe Light**

The strobe light is installed on top of the vertical stabilizer.

Strobe light is activated by a switch and is protected by a fuse. Switch and fuse are positioned on the instrument panel. The signal reaches a strobe light trigger circuit box positioned in the tail cone just behind the baggage compartment.

### 1.13 Pitot and Static Pressure Systems

The airspeed indicator system for the aircraft is shown below.

Below the left wing's leading edge the Pitot tube (1) while on the fuselage's sides there are two static ports (2). Two flexible hoses (3) feed the airspeed indicator (4), the altimeter (5) and the VSI (6) on the instrument panel.

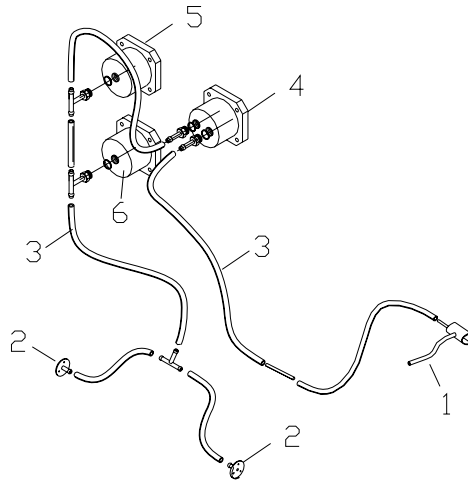

Fig.1-5 Pitot Static system

## 1.14 Landing Gear

The main landing gear consists of two special steel spring-leaf struts (1) positioned crossways to fuselage for elastic cushioning of landing loads.

The two steel spring-leaf struts are attached to the fuselage underside via the main girder.

Two rawhide liners (2 3) are inserted between each spring-leaf and the girder. Two bolts (5) and nuts secure the individual spring-leaf to the edge of the girder via a light alloy clamp (4) while a single bolt (6) and nut secures the inboard end of the leaf-spring to the girder.

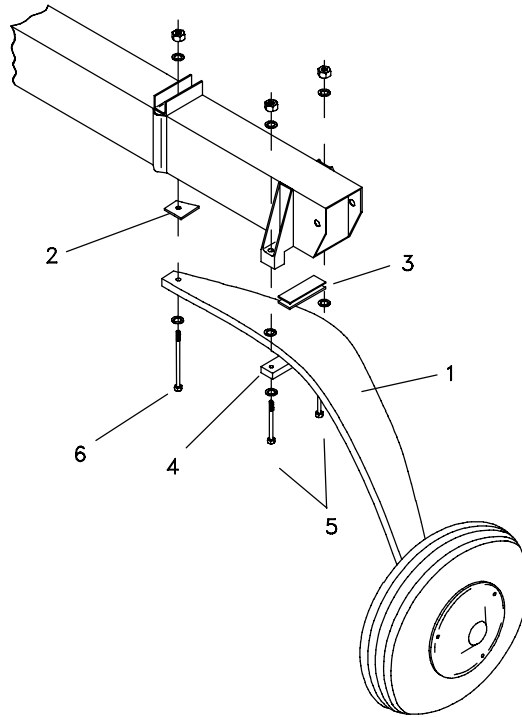

Figure 1-6 Main landing gear

Wheels are cantilevered on gear struts and feature hydraulically actuated disc brakes (see fig. 1-7) controlled by a lever (1) located on cabin tunnel between seats. Main gear wheels mount Air-Trac type 5.00-5 tires inflated at 1.6 bar (23 psi).

### 1.14.1 Brake System

The aircraft's brake system is a single-system acting on both wheels of the main landing gear through disk brakes. The same circuit acts as a parking brake by setting the parking brake.

To activate brakes verify that the brake shut-off valve positioned on tunnel between pilots is OFF, then activate brake lever as necessary. Pull brake lever and set the brake shut-valve to ON to activate parking brake.

The reservoir tank is located under the pilot's seat.

Hydraulic circuit shut-off valve (2) is positioned between seats. With circuit shut off, pulling emergency brake lever activates parking brake function.

Braking is simultaneous on both wheels via a "T" shaped joint (6).

Control lever (1) activates master cylinder (3) that features built-in brake-fluid reservoir (4). The brake system is equipped with a non-return valve (5), which insures that braking action is always effective even if parking brake circuit should accidentally be closed.

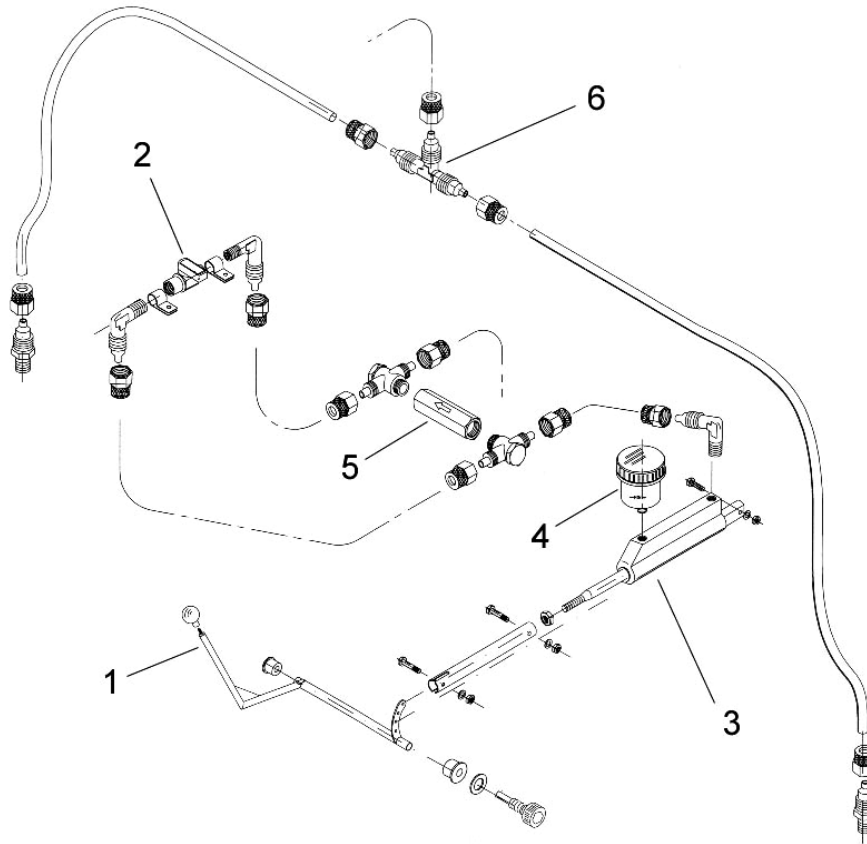

Fig. 1-7 Brake System

## SECTION 2 OPERATING LIMITATIONS

### 2 Introduction

Section 2 includes operating limitations, instrument markings, and basic placards necessary for safe operation of the P2004 Bravo, its engine, standard systems and standard equipment.

#### 2.1.1 Airspeed Limitations

SPEED		KIAS	REMARKS
V <sub>NE</sub>	Never exceed speed	138	Never exceed this speed in any operation
V <sub>NO</sub>	Maximum Structural Cruising Speed	110	Never exceed this speed unless in smooth air, and then only with caution
V <sub>A</sub>	Maneuvering speed	96	Do not make full or abrupt control movements above this speed as this may cause stress in excess of limit load factor
V <sub>FE</sub>	Maximum full flap extended speed	67	Never exceed this speed for any given flap setting over 15°.
V <sub>H</sub>	Maximum speed	120	Maximum speed in level flight at max continuous power (MSL)
V <sub>X</sub>	Best Angle Climb	60	The speed which results in the greatest gain of altitude in a given horizontal distance
V <sub>Y</sub>	Best Rate Climb	68	The speed which results in the greatest gain of altitude in a given time

#### 2.1.2 Airspeed Indicator Markings

Airspeed indicator markings and their color code are explained in the following table.

MARKING	KIAS	SIGNIFICANCE
White arc	26 - 67	Flap Operating Range (lower limit is V <sub>SO</sub> , at maximum weight and upper limit is the maximum speed permissible with full flaps)
Green arc	39 - 110	Normal Operating Range (lower limit is V <sub>S1</sub> at maximum weight and upper limit is maximum structural speed V <sub>NO</sub> )
Yellow arc	110 - 138	Operations must be conducted with caution and only in smooth air
Red line	138	Maximum speed for all operations

**2.1.3 Powerplant Limitations**

The following table lists operating limitations for aircraft installed engine:  
 Engine manufacturer: Bombardier Rotax GmbH.  
 Engine model: 912 ULS or S2

Maximum power: (see table below)

	Max Power kW (hp)	Max rpm. rpm prop.(engine)	Time max. (min.)
Max.	73.5 (98.5)	2388 (5800)	5
Max cont.	69 (92.5)	2265 (5500)	-

**NOTE**

Static engine rpm should be  $5100 \pm 250$  under no wind conditions.

**2.1.4 Temperatures**

Max cylinder heads	135° C
Max coolant	120° C
Max. / min. Oil	50° C / 130° C
Oil normal operating temperature (approx.)	90° C – 110° C

**2.1.5 Oil Pressure**

Minimum	0.8 bar	Below 3500 RPM
Normal	2.0 - 5.0 bar	Above 3500 RPM

**2.1.6 Operating & starting temperature range**

OAT Min	-25° C
OAT Max	+50° C

**Warning**

Admissible pressure for cold start is 7 bar maximum for short periods.

*For your information only*

Bar is a unit of measure. The word comes from the Greek baros, "weighty." We see the same root in our word, barometer, for an instrument measuring atmospheric pressure. One bar is just a bit less than the average pressure of the Earth's atmosphere, which is 1013.25 bar. In practice, meteorologists generally record atmospheric pressure in millibars (mb). In English-speaking countries, barometric pressure is also expressed as the height, in inches, of a column of mercury supported by the pressure of the atmosphere. In this unit, one bar equals 29.53 inches of mercury (in Hg) or 14.5 PSI.

**2.1.7 Fuel Pressure**

Min	0.15 bar
Max	0.40 bar

## 2.1.8 Lubricant

### 2.1.8.1 Viscosity

Use viscosity grade oil as specified in the Rotax Owners Manual

#### **Warning**

Use of Aviation Grade Oil with or without additives is not permitted

## 2.1.9 Coolant

Coolant type and specifications are detailed into the “Rotax Operator’s Manual” and in its related documents.

### 2.1.10 Propeller

Manufacturer:	F.lli Tonini Giancarlo & Felice S.n.c.
Model:	GT-2/173/VRO-SRTC FW 101
Propeller type:	Wood twin blade fixed pitch
Diameter:	1730 mm (68”) (no reduction permitted)

### 2.1.11 Fuel

Two tanks:	50 liters each (13.2 gallons)
Total fuel capacity:	100 liters (26.4 gallons)
Usable fuel quantity:	99 liters (26.2 gallons)

#### **NOTE**

During all phases of flight, both tanks normally supply engine fuel feed

#### **Warning**

Compensate for uneven fuel tank levels by closing the fuel valve on the tank with more fuel making sure that one fuel valve is in the on position at all times.

**2.1.12 Approved Fuel**

Min. RON 95 Auto Fuel (AKI 91 Premium USA)
AVGAS 100LL (see Warning below)

**Warning**

Prolonged use of Aviation Fuel Avgas 100LL results in greater wear of valve seats and greater combustion deposits inside cylinders due to higher lead content. It is therefore suggested to avoid using this type of fuel unless strictly necessary.

**2.1.13 Powerplant Instrument Markings**

Powerplant instrument markings and their color code significance are shown below:

Instrument		Red line Minimum limit	Green arc Normal operating	Yellow arc Caution	Red line Maximum limit
Engine Tach	Rpm	-----	1400-5500	5500-5800	5800
Oil Temp.	°C	50	90-110	50 - 90 110-130	130°C
Cylinder heads temp.	°C	-----	50 - 135	-----	135°C
Oil pressure	Bar	0.8	2 – 5	0.8 – 2 5 – 7	7
Fuel Pressure	PSI	2.2	2.2 – 5.8		5.8

**2.1.14 Other Instrument Markings**

Instrument	Red line Minimum limit	Green arc Normal operating	Yellow arc Caution	Red line Maximum limit
Voltmeter	10 Volt	12 - 14 Volt	----	----
Suction gauge (if installed)	4.0 in. Hg	4.5 – 5.5 in. Hg	----	----

**2.1.15 Weights**

Maximum takeoff weight:	600 kg (1320 lbs)
Maximum landing weight:	600 kg (1320 lbs)
Maximum baggage weight:	20 kg (44 lbs)

**2.1.16 Center of Gravity Range**

Forward limit	25.0% MAC 1.724 m (68") aft of datum for all weights
Aft limit	29.0% MAC 1.778 m (70") aft of datum for all weights
Datum	Propeller support flange without spacer
Ref. for leveling	Cabin floor (ref. to Maintenance Manual)

**Warning**

It is the pilot's responsibility to insure that airplane is properly loaded.

**2.1.17 Approved Maneuvers**

This aircraft is intended for non-aerobatic operation only. Non-aerobatic operation includes:

- Any maneuver pertaining to “normal” flight
- Stalls (except whip stalls)
- Lazy eights
- Chandelles
- Turns in which the angle of bank is not more than 60°
- Acrobatic maneuvers, including spins, are not approved

Recommended entry speeds for each approved maneuver are as follows:

Maneuver	Speed (KIAS)
Lazy eight	96
Chandelle	96
Steep turn (max 60°)	96
Stall	Slow deceleration (1 kts/s)

Limit load factor could be exceeded by moving the flight controls abruptly to full control deflection at a speed above  $V_A$  (96 KIAS, Maneuvering Speed).

**2.1.18 Maneuvering Load Factor Limits**

Maneuvering load factors are as follows:

Flaps		
0°	+4	-2
40°	+1.9	0

**2.1.18.1 Flight Crew**

Minimum crew for flight is one pilot seated on the left side.

**2.1.18.2 Maximum passenger seating**

With the exception of the pilot, only one passenger is allowed on board of this aircraft.

**2.1.19 Kinds of Operation**
**2.1.19.1 Day VFR**

The airplane, in standard configuration, is approved only for day VFR operations under VMC:

- Altimeter
- Airspeed Indicator
- Compass
- Fuel Gauges
- Oil Pressure Indicator
- Oil Temp. Indicator
- Cylinder Head Temp. Indicator
- Tachometer

Flight into expected and/or known-icing conditions is prohibited

**2.1.20 Night**

Night flight is approved if the aircraft is equipped as per the ASTM standard F2245-06 A2. LIGHT AIRCRAFT TO BE FLOWN AT NIGHT as well as any pertinent FAR.

**NOTE**

The FAA requires that the pilot possesses a minimum of a Private Pilot certificate and a current medical to fly at night. See the FARs for more information.

**2.1.21 IFR**

TBA

**2.1.22 Demonstrated Crosswind Safe Operations**

The aircraft controllability during take-offs and landings have been demonstrated with a crosswind component of 15 knots

**2.1.23 Service Ceiling**

13,110'

**2.1.24 Limitation Placards**

See Section 8

## SECTION 3 WEIGHT & BALANCE

### 3 Introduction

This section describes the procedure for establishing the basic empty weight and moment of the aircraft. Loading procedure information is also provided.

#### 3.1 Aircraft weighing procedures

##### 3.1.1 Preparation

- Carry out weighing procedure inside closed hangar
- Remove from cabin any objects left unintentionally
- Insure on board presence of the Flight Manual
- Align nose wheel
- Drain fuel via the specific drain valve.
- Oil, hydraulic fluid and coolant to operating levels
- Move sliding seats to most forward position
- Raise flaps to fully retracted position (0°)
- Place control surfaces in neutral position
- Place scales (min. capacity 200 kg) under each wheel

##### 3.1.2 Leveling

Level the aircraft both longitudinal and transverse (see Maintenance Manual – Section B “Inspection and Servicing”)

##### 3.1.3 Weighing

- Record weight shown on each scale
- Repeat weighing procedure three times
- Calculate empty weight

##### 3.1.4 Determination of C.G. location

- Drop a plumb bob tangent to the leading edge (at 15mm (0.59”) inboard respect the rib #7 riveting line) and trace reference mark on the floor
- Repeat operation for other half-wing
- Stretch a taught line between the two marks
- Measure the distance between the reference line and main wheel axis
- Using recorded data it is possible to determine the aircraft's C.G. location and moment (see following table)

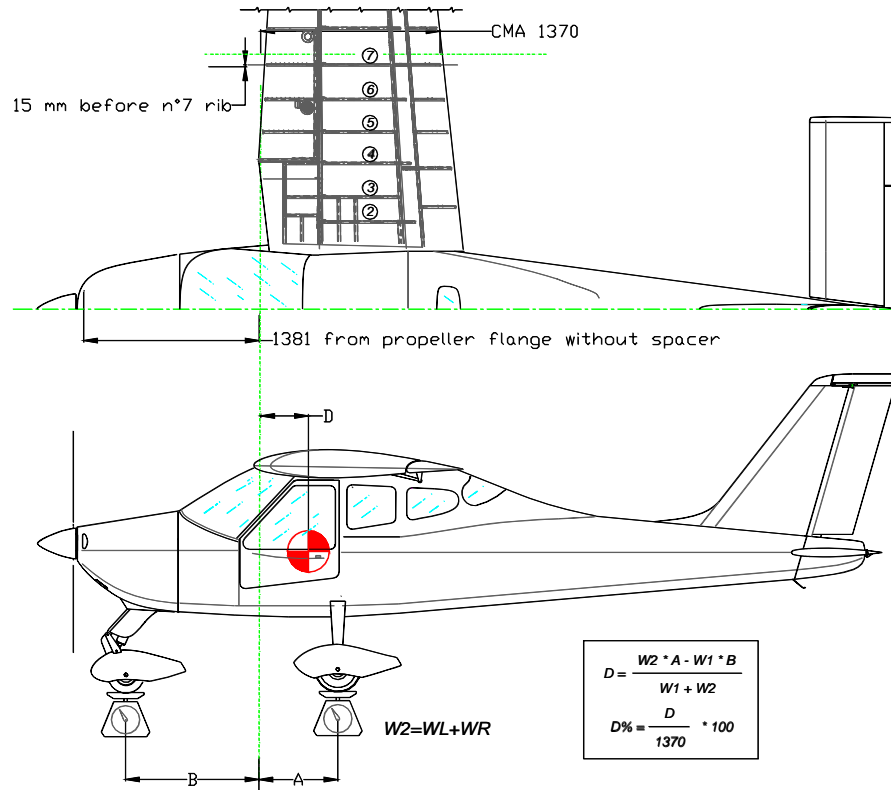
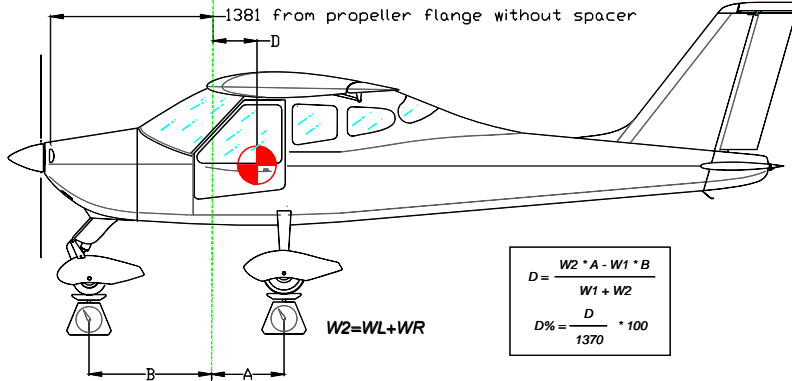

Fig.3-1

**3.1.5 Weighing Report**

Model P2004 Bravo S/N: \_\_\_\_\_ Weighing n° \_\_\_\_ Date: \_\_\_\_\_  
Datum: Propeller support flange without spacer.



	Kg		meters
Nose wheel weight	W1 =	Plumb bob distance(1) LH wheel	AL =
LH wheel weight	WL =	Plumb bob distance(1) RH wheel	AR =
RH wheel weight	WR =	Average distance (AL+ AR)/2	A =
W2 = WL+WR =		Bob distance from nose wheel(1)	B =

Empty weight  $W_e = W1 + W2 =$

$D = \frac{W_2 \cdot A - W_1 \cdot B}{W_e} =$	m	$D\% = \frac{D}{1.370} \cdot 100 =$
-----------------------------------------------	---	-------------------------------------

Empty weight moment:  $M = [(D+1.381) \cdot W_e] =$  Kg. m

Maximum takeoff weight	WT =
Empty weight	W <sub>e</sub> =
Maximum payload WT - W <sub>e</sub>	W <sub>u</sub> =

(1) To determine the Mean Aerodynamic Chord (MAC) and the plumb line see FIG. 3-1.

**3.1.6 Center of Gravity Range**

Forward limit	25.0% MAC 1.724 m (~68") aft of datum for all weights
Aft limit	29.0% MAC 1.778 m (~70") aft of datum for all weights
Datum	Propeller support flange without spacer
Ref. for leveling	Cabin floor (ref. to Maintenance Manual)

### 3.1.7 Distances from the datum

The mean distances of the occupants, baggage and fuel from the datum are:

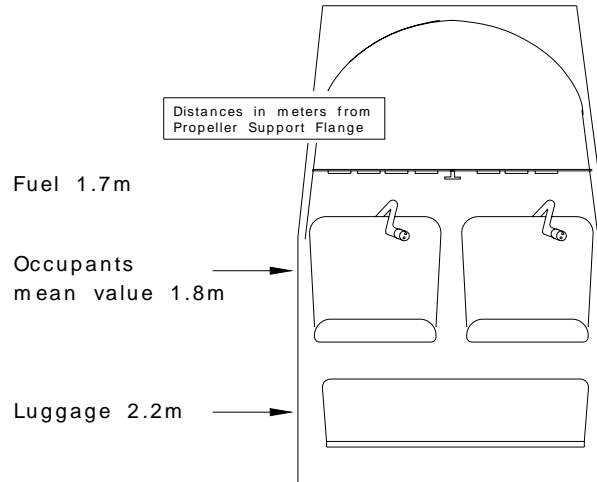

Figure 3-2

### 3.2 Weight and Balance

In order to compute the weight and balance of this aircraft, we have provided the following loading charts. This will reduce the amount of math you need. To compute weight and balance we use the formula:

$$\text{Weight} * \text{Arm} = \text{Moment.}$$

Pilot & Passenger					Fuel		Baggage	
Weight	Moment			Gallons	Weight	Moment	Weight	Moment
10	708.70	260	18426.10	1	6	401.59	5	433.09
20	1417.39	270	19134.79	2	12	803.19	10	866.18
30	2126.09	280	19843.49	3	18	1204.78	15	1299.28
40	2834.78	290	20552.18	4	24	1606.38	20	1732.37
50	3543.48	300	21260.88	5	30	2007.97	25	2165.46
60	4252.18	310	21969.58	6	36	2409.57	30	2598.55
70	4960.87	320	22678.27	7	42	2811.16	35	3031.64
80	5669.57	330	23386.97	8	48	3212.76	40	3464.74
90	6378.26	340	24095.66	9	54	3614.35	44	3811.21
100	7086.96	350	24804.36	10	60	4015.94		
110	7795.66	360	25513.06	11	66	4417.54		
120	8504.35	370	26221.75	12	72	4819.13		
130	9213.05	380	26930.45	13	78	5220.73		
140	9921.74	390	27639.14	14	84	5622.32		
150	10630.44	400	28347.84	15	90	6023.92		
160	11339.14	410	29056.54	16	96	6425.51		
170	12047.83	420	29765.23	17	102	6827.10		
180	12756.53	430	30473.93	18	108	7228.70		
190	13465.22	440	31182.62	19	114	7630.29		
200	14173.92	450	31891.32	20	120	8031.89		
210	14882.62	460	32600.02	21	126	8433.48		
220	15591.31	470	33308.71	22	132	8835.08		
230	16300.01	480	34017.41	23	138	9236.67		
240	17008.70	490	34726.10	24	144	9638.27		
250	17717.40	500	35434.80	25	150	10039.86		
				26	156	10441.45		

Meters	Inches	
1.7	66.9324	Fuel
1.8	70.8696	Pax
2.2	86.6184	Baggage

All you need to do is find the weight and moment and insert them into the following Computation Chart.

<b>Computation Chart</b>			
	Weight (lbs)	Arm (inches)	Moment
Empty Weight			
Fuel		66.9324	
Pilot & Passenger		70.8696	
Baggage		86.6184	
Totals			

<b>C.G. Range</b>		
Meters	1.7240	1.7780
Inches	67.8773	70.0034

Maximum gross weight is 600 kg (1320 pounds)

Plug the weight numbers in the Weight column and the moment numbers in the Moment column. Divide the total moment by the total weight to get the arm. This number should fall within the C.G. Range listed above.

<b>Example Problem</b>			
	Weight (lbs)	Arm (inches)	Moment
Empty Weight	748.9	67.79	50767.93
Fuel	150	66.9324	10039.86
Pilot & Passenger	300	70.8696	21260.88
Baggage	20	86.6184	1732.368
Totals	1218.9	68.7513652	83801.04

In this example, the gross weight is under the max gross weight of 600 kg (1320 lbs) and the Arm or C.G. is within the C.G. range listed above.

### 3.2.1 Loading

Baggage compartment is designed for a maximum load of 20 kg (44 lbs). Baggage must be secured using a tie-down net to prevent any baggage movement during maneuvers.

### 3.3 Equipment List

The following is a comprehensive list of TECNAM standard and optional supplied equipment for the Bravo. Some of the equipment may not be installed in your airplane. The list consists of the following groups:

- A. Engine and accessories
- B. Landing gear
- C. Electrical system
- D. Instruments
- E. Avionics

The following information describes each listing:

- Part-number to uniquely identify the item type
- Item description
- Serial number
- Weight in kilograms
- Distance in meters from datum

**NOTE**

Items marked with an asterisk (\*) are part of the basic installation.

Equipment list		A/C s/n		Date:	
Ref.	Description & p/n	s/n	Inst	Weight kg	Datum m
<b>Engine &amp; accessories</b>					
A1	Engine Rotax 912S2 or 912ULS		*	61.0	0.32
A2	Propeller Tonini GT-2/173/VRR-SRTC FW101		*	6.0	-0.13
A3	Exhaust and manifolds - p/n 973670	--	*	4.50	0.55
A4	Heat exchanger - p/n 92-11-830	--	*	2.00	0.55
A5	Oil Reservoir (full) - p/n 956.137	--	*	4.00	0.64
A6	Oil radiator - p/n 886 025	--	*	0.40	0.07
A7	Liquid coolant radiator. - p/n 995.697	--	*	0.90	0.33
A8	Air filter K&N - p/n 33-2544	--	*	0.40	0.60
A9	Fuel pump p/n 21-11-342-000	--	*	0.10	0.71
<b>Landing gear and accessories</b>					
B1	Main gear spring-leafs - p/n 92-8-300-1	--	*	5.700	1.94
B2	Main gear wheel rims. - Cleveland 40-78B	--	*	2.050	1.94
B3	Main gear tires.-Air Trac 5.00-5 AA1D4	--	*	2.580	1.94
B4	Disk brakes – Marc Ingegno	--	*	0.800	1.94
B5	Nose gear wheel rim - p/n 92-8-880-1	--	*	1.300	0.310
B6	Nose gear tire - Sava 4.00-6	--	*	1.200	0.460
B7	Nose gear fairing p/n 92-8-410-1/2	--	*	1.500	0.460
B8	Main gear fairing p/n 92-8-420-1/2	--	*	1.500	1.930
B9	Nose gear shock p/n 92-8-200-000	--	*	1.450	0.465

Equipment list		A/C S/N		Date:	
Ref.	Description & p/n	s/n	Inst	Weight kg	Datum m
	<b>Electrical system</b>				
C1	Battery FIAMM 6H4P 12V 18Ah		*	6.00	0.71
C2	Regulator, rectifier - p/n 945.345		*	0.20	0.82
C3	Battery relay - p/n 111-226-5		*	0.30	2.59
C4	Flaps actuator control - CALA33X150/c21A		*	2.20	2.30
C5	Trim actuator control MAC6A		*	0.40	5.73
C6	Overvoltage sensor OS75-14 or ZEFTRONICS V1510A		*	0.30	0.80
C7	Strobe light - AS A555A-V-14V			0.15	5.89
C8	Navigation lights - AS W1285			0.15	1.75
C9	Stall warning - AS 164R			0.10	1.36
C10	Landing light - AS GE 4509		*	0.50	1.38
	<b>Instruments</b>				
D1	Altimeter United Instruments p/n 5934PM-3 or LUN 1128.10B4 –TSO C10b		*	0.39	1.35
D2	Airspeed Ind. – UMA T6-311-161 - TSO C2b		*	0.30	1.35
D3	Compass - Airpath C2300- TSO		*	0.29	1.35
D4	Clock - Quartz Chronometer LC2 AT420100			0.15	1.35
D5	Vertical speed indicator – VSI 2FM-3		*	0.35	1.35
D6	Turn and Bank Indicator – FALCON GAUGER TC02E-3-1			0.56	1.35
D7	Attitude Indicator - GH-02V-3			1.10	1.35
D8	Directional Gyro – FALCON GAUGER DG02V-3			1.10	1.35
D9	OAT Indicator – VDO 397035001G			0.05	1.35
D10	Oil & head temp. Indicator VDO 641-011- 7047/-7048		*	0.10	1.35
D11	Oil Temp. Ind. - VDO 644-001-7030		*	0.10	1.35
D12	Trim Position Indicator -MAC S6A		*	0.05	1.35
D13	Engine RPM Ind. Aircraft Mitchell. D1- 112-5041		*	1.10	1.35
D14	Fuel Quantity Ind. Road GmbH XID4000800		*	0.56	1.35
D15	Voltmeter Ind. VDO 190-037-001G or Speed Com Instruments 0203		*	010	1.35
D16	Fuel Pressure Ind. Mitchell Aircraft Inst. 10-25-058		*	010	1.35

Equipment list		A/C s/n		Date:	
Ref.	Description & p/n	s/n	Inst	Weight kg	Datum m
	<b>Avionics</b>				
E1	Nav/Comm Trans.-Bendix/King, KX155			2.24	1.35
E2	Nav Indicator - Bendix/King KI208			0.46	1.35
E3	Transponder - Bendix/King KT76A			1.36	1.35
E4	GPS/NAV Receiver and R/T COM GNS 430			2.31	1.35
E5	R/T VHF COMM ICOM IC-A200			1.20	1.35
E6	ELT ACK - Model E-01			1.10	2.74
E7	Transponder-Garmin GTX320			1.00	1.35
E7	Transponder-Garmin GTX327			1.00	1.35
E8	Audio panel -Garmin GMA 340			0.50	1.35
E9	Vor/Loc Indicator-Garmin GI106A			0.64	1.35
E10	Transponder Antenna-Bendix/King KA60			0.17	1.09
E11	Transponder Antenna Garmin GTX320/327			0.17	1.09
E12	Mic - Telex TRA 100			0.17	1.90
E13	GPS Antenna Garmin GA56			0.27	1.08
E14	Comm Antenna Command Industries CI 291			0.34	3.30
E15	VOR/ILS Antenna. Command Industries CI 138C			0.26	5.80
E16	ELT Antenna Kit Model E-01			0.21	2.70
E17	Fire Extinguisher Enterprises Ltd BA51015-3			2.20	2.32
E18	First Aid Kit			0.28	2.30
E19	Altitude Encoder- Amery King Ak-30			0.25	1.00
E20	Emergency Hammer-Dmail 108126			0.35	2.30

## SECTION 4 PERFORMANCE

### 4 Introduction

This section provides all necessary data for accurate and comprehensive planning of flight activity from takeoff to landing. Data reported in graphs and/or in tables were determined using:

- “Flight Test Data”
- Aircraft and engine in good condition
- Average piloting techniques

Each graph or table was determined according to ICAO Standard Atmosphere (ISA - MSL); evaluations of the impact on performance were carried out by theoretical means for:

- Airspeed
- External temperature
- Altitude
- Weight
- Type and condition of runway

#### 4.1 Use of Performance Charts

Performance data is presented in tabular or graphical form to illustrate the effect of different variables such as altitude, temperature and weight. Given information is sufficient to plan journey with required precision and safety. Additional information is provided for each table or graph.

**4.1.1 Conversion Charts**
**4.1.1.1 Kilogram to pound conversion chart**

<b>Kilograms</b>	<b>Multiply by</b>	<b>Pounds</b>		<b>Kilograms</b>	<b>Multiply by</b>	<b>Pounds</b>
400	2.205	882.00		500	2.205	1102.50
410	2.205	904.05		510	2.205	1124.55
420	2.205	926.10		520	2.205	1146.60
430	2.205	948.15		530	2.205	1168.65
440	2.205	970.20		540	2.205	1190.70
450	2.205	992.25		550	2.205	1212.75
460	2.205	1014.30		560	2.205	1234.80
470	2.205	1036.35		570	2.205	1256.85
480	2.205	1058.40		580	2.205	1278.90
490	2.205	1080.45		590	2.205	1300.95
				599	2.205	1320.80

**4.1.1.2 Meters to Feet**

<b>Meters</b>	<b>Multiply by</b>	<b>Feet</b>		<b>Meters</b>	<b>Multiply by</b>	<b>Feet</b>
50	3.281	164.05		180	3.281	590.58
60	3.281	196.86		190	3.281	623.39
70	3.281	229.67		200	3.281	656.2
80	3.281	262.48		210	3.281	689.01
90	3.281	295.29		220	3.281	721.82
100	3.281	328.1		230	3.281	754.63
110	3.281	360.91		240	3.281	787.44
120	3.281	393.72		250	3.281	820.25
130	3.281	426.53		260	3.281	853.06
140	3.281	459.34		270	3.281	885.87
150	3.281	492.15		280	3.281	918.68
160	3.281	524.96		290	3.281	951.49
170	3.281	557.77		300	3.281	984.3

**4.1.1.3 Kilometers to Knots**

<b>Kilometers</b>	<b>Multiply by</b>	<b>Knots</b>		<b>Kilometers</b>	<b>Multiply by</b>	<b>Knots</b>
50	0.5396	26.98		150	0.5396	80.94
60	0.5396	32.376		160	0.5396	86.336
70	0.5396	37.772		170	0.5396	91.732
80	0.5396	43.168		180	0.5396	97.128
90	0.5396	48.564		190	0.5396	102.524
100	0.5396	53.96		200	0.5396	107.92
110	0.5396	59.356		210	0.5396	113.316
120	0.5396	64.752		220	0.5396	118.712
130	0.5396	70.148		230	0.5396	124.108
140	0.5396	75.544		240	0.5396	129.504
				250	0.5396	134.9

#### 4.1.2 Airspeed Indicator System Calibration

Graph shows calibrated airspeed VCAS as a function of indicated airspeed VIAS.

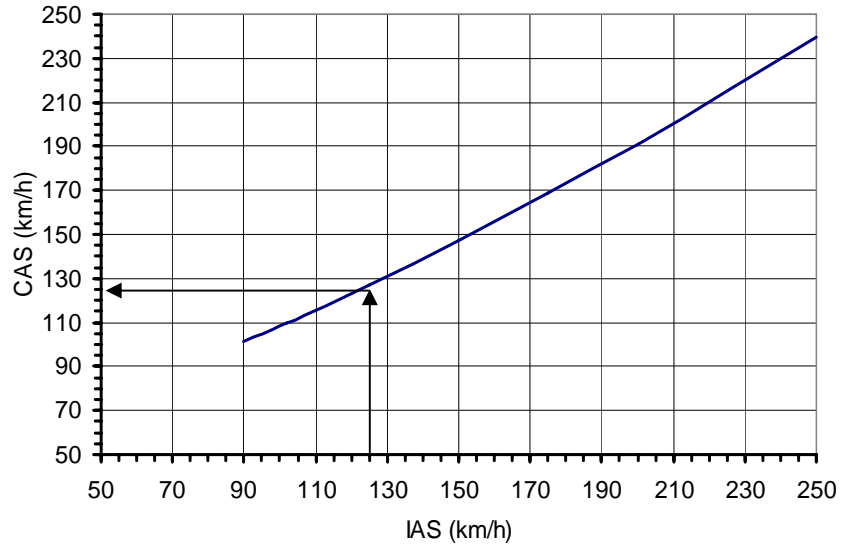

Fig. 4-1 Calibrated vs. Indicated Airspeed

⇒ Example:

Given  
VIAS = 125 km/h

Find  
VCAS = 127 km/h

**NOTE**

Indicated airspeed assumes no instrument error

4.1.3 ICAO Chart

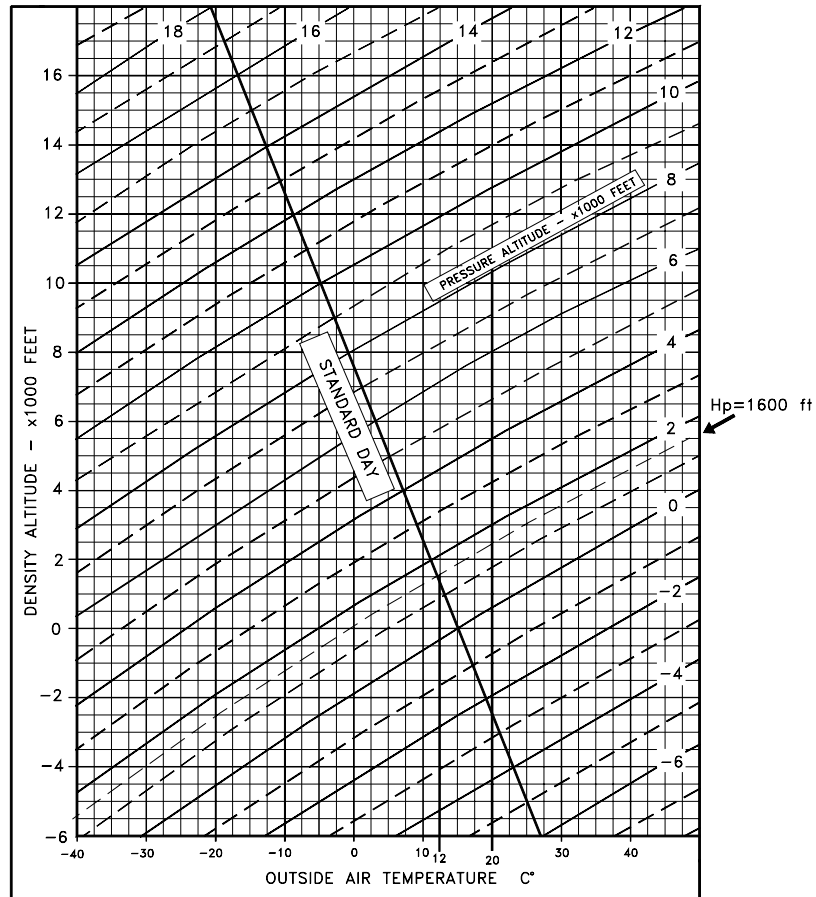

Fig.4-2. ICAO Chart

⇒ Example:

Given

Temperature = 20°C

Pressure Altitude = 1600 ft

Find

$T_s = 12^\circ$

**4.1.4 Stall Speed**

## CONDITIONS:

- Weight 1320 lbs
- Engine Idle
- No ground effect

**NOTE**

Altitude loss during conventional stall recovery as demonstrated during test flights is approximately 100 ft with banking under 30°

LATERAL BANKING				
FLAPS	0°	30°	45°	60°
0°	40	42	45	55
15°	37	41	43	52
40°	35	37	42	49

### 4.1.5 Crosswind

Maximum demonstrated crosswind velocity is 15 knots

⇒ Example:

Given

Wind direction = 30°

Find

Headwind = 17.5 Knots

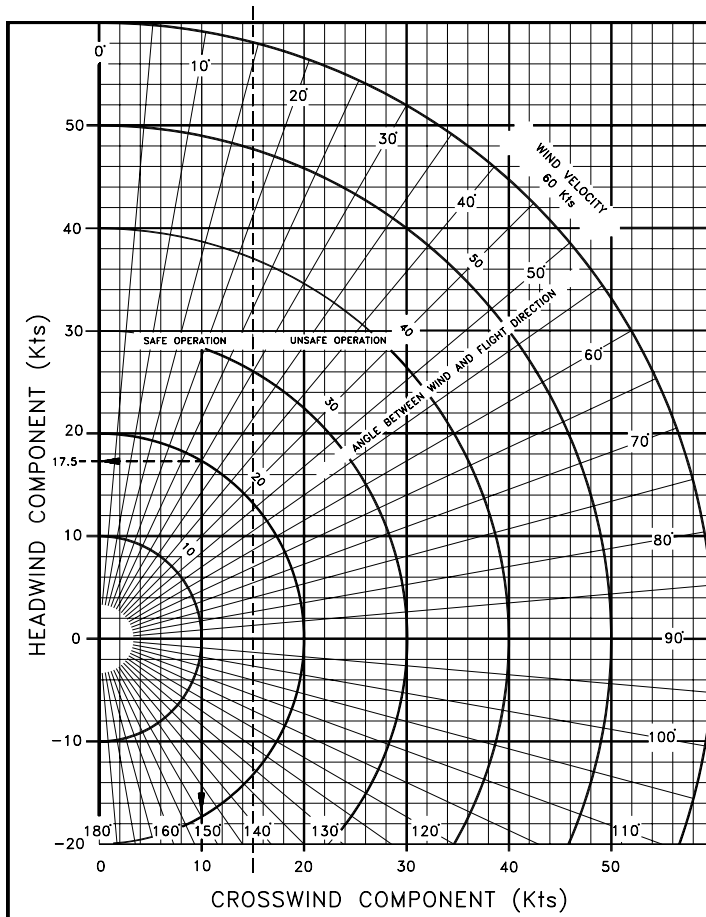

Wind velocity = 20 Kts

Crosswind = 10 Knots

Fig.4-3.Crosswind chart

**4.1.6 Takeoff performance**

**TAKEOFF DISTANCE**

Conditions:

ISA

Engine: Full throttle

(see Sect.4 – Takeoff and climb)

Runway: dry, compact, grass

Flap: 15°

Slope: 0°

Wind: zero

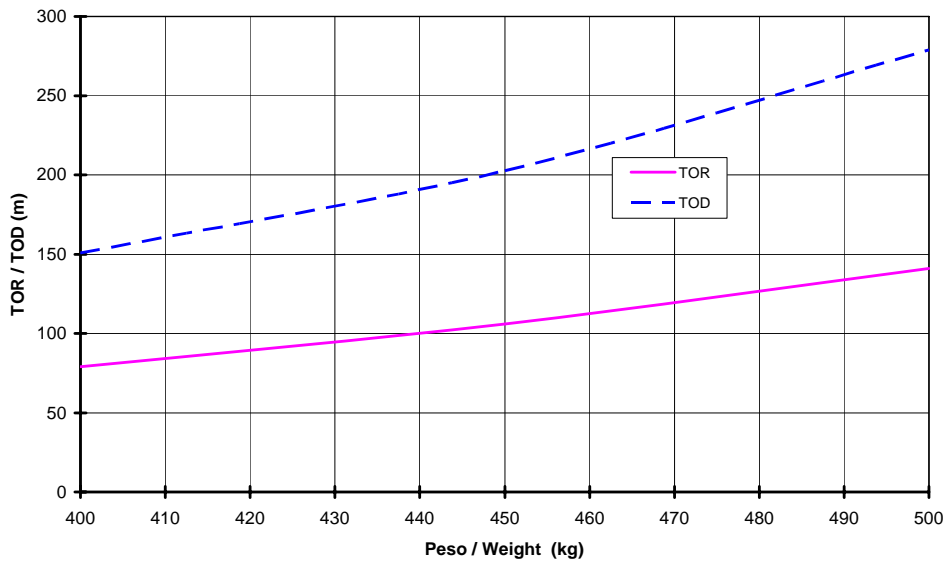

Fig. 4-4 Takeoff Performance

**4.1.7 Climb Performance**

**CLIMB RATE IN CLEAN CONFIGURATION**

Conditions:

Flap: 0°

Engine: Full throttle

$V_Y = 68$  Knots IAS - R/C residual: 100 ft/min.

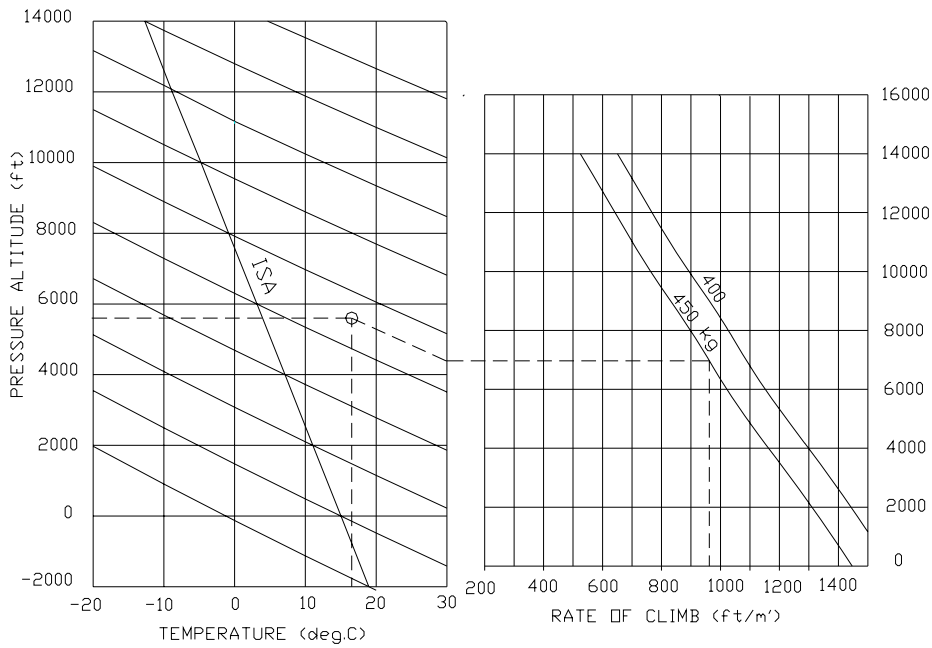

Fig. 4-5 Climb

⇒ Example:

Given

O.A.T. = 17°C

Pressure altitude = 5600 ft

Weight = 1320 lbs

Find

Rate of climb = 860 ft/min

## 4.2 Cruise

- Maximum takeoff weight = 600 kg (1320 lbs)
- Fuel tanks 2x50 liters (13.2 gal) (less the unusable fuel)

Pressure altitude  $H_p$ : **0 ft** OAT: **+15°C**

Engine RPM	Speed KTAS	Consumption (gal/h)	1 Endurance (hrs)		<sup>1</sup> Range (N.m.)	
55%	4600	100	4	6.5	650	
65%	5000	106	4.8	5.5	583	
75%	5200	113	5.3	4.9	553	

Pressure altitude  $H_p$ : **2000 ft** OAT: **+11°C**

Engine RPM	Speed KTAS	Consumption (gal/h)	1 Endurance (hrs)		<sup>1</sup> Range (N.m.)	
55%	4600	102	4	6.5	663	
65%	5000	108	4.8	5.5	594	
73%	5200	114	5.2	5.0	570	

Pressure altitude  $H_p$ : **4000 ft** OAT: **+7°C**

Engine RPM	Speed KTAS	Consumption (gal/h)	1 Endurance (hrs)		<sup>1</sup> Range (N.m.)	
55%	4600	106	4	6.5	689	
60%	5000	108	4.5	5.8	626	
70%	5200	114	4.9	5.3	604	

Pressure altitude  $H_p$ : **6000 ft** OAT: **+3°C**

Propeller RPM	Speed KTAS	Consumption (gal/h)	1 Endurance (hrs)		<sup>1</sup> Range (N.m.)	
55%	5000	107	4	6.5	695	
60%	5200	109	4.5	5.8	632	

<sup>1</sup> Range and endurance are intended approximate and referred to a "zero" wind condition.

Pressure altitude  $H_p$ : **8000 ft** OAT: **-0.8°C**

Propeller RPM	Speed KTAS	Consumption (gal/h)	1 Endurance (hrs)		<sup>1</sup> Range (N.m.)	
55%	5150	108	4	6.5	702	
58%	5200	110	4.3	6.0	660	

Pressure altitude  $H_p$ : **10000 ft** OAT: **-5°C**

Propeller RPM	Speed KTAS	Consumption (gal/h)	1 Endurance (hrs)		<sup>1</sup> Range (N.m.)	
55%	5200	108	4	6.5	702	

Pressure altitude  $H_p$ : **12000 ft** OAT: **-9°C**

Propeller RPM	Speed KTAS	Consumption (gal/h)	1 Endurance (hrs)		<sup>1</sup> Range (N.m.)	
50%	5200	104	3.7	7.0	728	

### 4.2.1 Landing Distance

Conditions:

Flap: 40°

Engine: idle

Runway: dry, compact, grass

Slope: 0°

Wind: zero

Distance over a 50' high obstacle

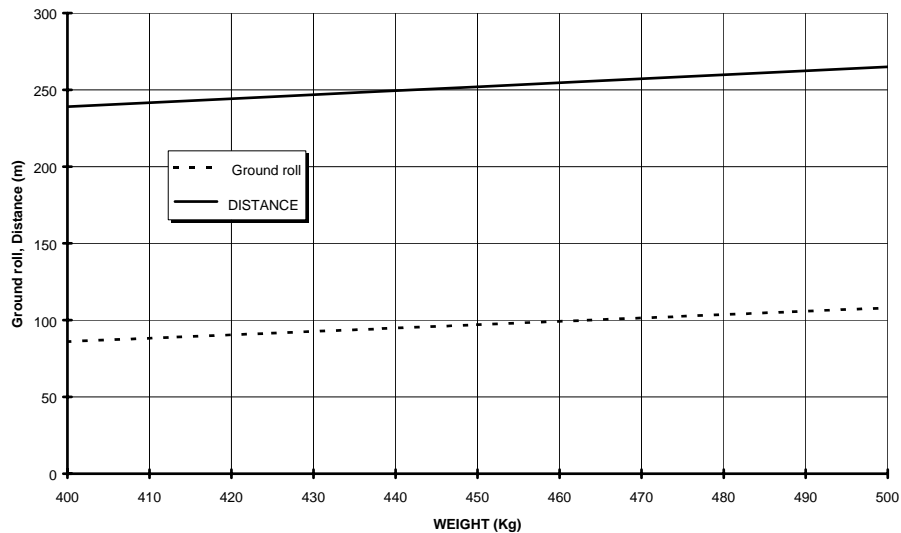

Fig. 4-7 Landing

### 4.3 Effects of Rain and Insects

Flight test have demonstrated that neither rain nor insect impact build-up on leading edge have caused substantial variations to aircraft's flight qualities. Such variations do not exceed: 5 kts for stalls, 100 ft/min for climb, and 165' for takeoff runs.

### 4.4 Noise Data

Noise level was determined according to EASA CS-36 1st edition dated 17th October 2003, with reference to ICAO/Annex 16 3rd edition dated 1993, Vol. I° chapter 10, and resulted equal to 62.36 db.

## SECTION 5 EMERGENCY PROCEDURES

### 5 Introduction

Section 6 includes checklists and detailed procedures to be used in the event of emergencies. Emergencies caused by a malfunction of the aircraft or engine are extremely rare if appropriate maintenance and pre-flight inspections are carried out.

In case of emergency, suggestions of the present section should be considered and applied as necessary to correct the problem.

Before operating the aircraft, the pilot should become thoroughly familiar with the present manual and, in particular, with the present section. Further, a continued and appropriate training program should be provided.

In case of emergency the pilot should act as follows:

- Keep control of the airplane
- Analyze the situation
- Apply the pertinent procedure
- Inform the Air Traffic Control if time and conditions allow

<b>AIRSPEEDS FOR SAFE OPERATION IN EMERGENCY SITUATIONS - IAS</b>	
Engine failure after takeoff (15 degrees of flaps)	<b>60 Kts</b>
Engine failure during flight	<b>68 Kts</b>
Maneuvering speed	<b>96 Kts</b>
Maximum glide	<b>68 Kts</b>

## 5.1 Engine Failures

If an emergency arises, the basic guidelines described in this section should be considered and applied as necessary to correct the problem.

### 5.1.1 Engine Failures on Ground

#### 5.1.1.1 ENGINE FAILURE DURING TAKEOFF RUN

Throttle: ..... IDLE  
 Brakes: ..... APPLY  
 Ignition Switches: ..... OFF  
 Master switch: ..... OFF  
*When the airplane is under control*  
 Fuel selector valves: ..... OFF  
 Electric fuel pump: ..... OFF

### 5.1.2 Engine Failure during Flight

#### 5.1.2.1 ENGINE FAILURE IMMEDIATELY AFTER TAKEOFF

Airspeed: ..... 60 knots  
*Find a suitable place on the ground to land safely. The landing should be planned straight ahead with only small changes in directions not exceeding 45° to the left or 45° to the right*

Flaps: ..... AS REQUIRED

*At touch down:*

Throttle: ..... IDLE  
 Ignition Switches: ..... OFF  
 Master switch: ..... OFF  
 Fuel selector valves: ..... OFF  
 Electric fuel pump: ..... OFF

#### 5.1.2.2 IRREGULAR ENGINE RPM

Throttle: ..... CHECK  
 Engine gauges: ..... CHECK  
 Fuel quantity indicators: ..... CHECK  
 Carburetor heat (optional): ..... ON  
 Electric fuel pump: ..... ON

*If the engine continues to run irregularly:*

Fuel selector valves: ..... BOTH ON

*If the engine continues to run irregularly:*

Land as soon as possible

#### 5.1.2.3 LOW FUEL PRESSURE

If the fuel pressure indicator falls below the (0.15 bar) limit:

Fuel quantity indicators: ..... CHECK  
 Electric fuel pump: ..... ON

*If the engine continues to run irregularly:*

Fuel selector valves: ..... BOTH ON

*If the fuel pressure continues to be low:*

Land as soon as possible

**5.1.2.4 LOW OIL PRESSURE**

- Oil temperature:..... CHECK  
*If the temperature tends to increase:*  
 If stable within the green arc: ..... LAND as soon as possible  
 If increasing:..... LAND as soon as possible and be alert for impending engine failure

**5.1.2.5 IN-FLIGHT ENGINE RESTART**

- Altitude:..... Below 4000 ft Preferred  
 Carburetor heat (if installed): ..... ON  
 Electric fuel pump: ..... ON  
 Fuel selector valves: ..... BOTH ON  
 Throttle:..... MIDDLE POSITION  
 Ignition switches: ..... ON  
 Master Switch:..... START  
*If the restart attempt fails:*  
 Procedure for a forced landing: ..... APPLY  
*In case of an engine restart:*  
 Land as soon as possible

**5.1.2.6 ENGINE OUT GLIDE**

- Flaps: ..... RETRACT  
 Speed: ..... 68 KIAS  
 Electric equipments: ..... OFF  
 In-flight engine restart: ..... If conditions permit, try to restart several times

**NOTE**

Glide ratio is 12.8:1 therefore with 1000 ft of altitude; it is possible to cover ~2 nautical miles in zero wind conditions.

**5.2 Smoke and Fire**
**5.2.1 Engine Fire while parked**

- Fuel selector valves: ..... OFF  
 Electric fuel pump: ..... OFF  
 Ignition Switches:..... OFF  
 Master switch: ..... OFF  
 Parking brake: ..... SET  
 Escape rapidly from the aircraft

**5.2.2 Engine Fire during Takeoff**

- Throttle:..... IDLE  
 Brakes:..... AS NEEDED  
*With the airplane is under control:*  
 Fuel selector valves: ..... OFF  
 Electric fuel pump: ..... OFF  
 Cabin heating: ..... OFF  
 Ignition Switches:..... OFF  
 Master switch: ..... OFF  
 Parking brake: ..... SET  
 Escape rapidly from the aircraft

**5.2.3 Engine Fire in-flight**

Cabin heat: ..... OFF  
 Fuel selector valves: ..... OFF  
 Electric fuel pump: ..... OFF  
 Throttle: ..... FULL IN until the engine stops running  
 Cabin vents: ..... OPEN  
 Ignition Switches: ..... OFF  
*Do not attempt an in-flight restart*  
 Procedure for a forced landing: ..... APPLY

**5.2.4 Cabin Fire during Flight**

Cabin heat: ..... OFF  
 Cabin vents: ..... OPEN  
 Doors: ..... OPEN, if necessary  
 Master switch: ..... OFF  
 Try to choke the fire. Direct the fire extinguisher towards flame base  
 Procedure for a forced landing: ..... APPLY

**5.3 Landing Emergency**
**5.3.1.1 FORCED LANDING WITHOUT ENGINE POWER**

Descent: ..... ESTABLISH  
 Airspeed: ..... 68 KIAS  
 Select terrain area most suitable for emergency landing and flyby checking for obstacles and wind direction  
 Fuel selector valves: ..... OFF  
 Electric fuel pump: ..... OFF  
 Ignition Switches: ..... OFF  
 Safety belts: ..... TIGHTEN  
 Doors: ..... UNLATCHED  
*Landing assured:*  
 Flaps: ..... AS NECESSARY  
 Master switch: ..... OFF  
 Touchdown Speed: ..... 42 KIAS (full flaps)

**5.3.1.2 POWER-ON FORCED LANDING**

Descent: ..... ESTABLISH  
 Establish: ..... 68 KIAS  
 Flaps: ..... AS NECESSARY  
 Select terrain area most suitable for emergency landing and flyby checking for obstacles and wind direction  
 Safety belts: ..... TIGHTEN  
 Doors: ..... UNLOCK  
*Landing assured:*  
 Flaps: ..... AS NECESSARY  
 Fuel selector valves: ..... OFF  
 Electric fuel pump: ..... OFF  
 Ignition Switches: ..... OFF  
 Master switch: ..... OFF

**5.3.1.3 LANDING WITH A FLAT NOSE TIRE**

Pre-landing checklist: ..... COMPLETE  
 Flaps: ..... FULL  
 Land and maintain aircraft NOSE HIGH attitude as long as possible

**5.3.1.4 LANDING WITH A FLAT MAIN TIRE**

Pre-landing checklist: ..... COMPLETE

Flaps: ..... FULL

**NOTE**

Align the airplane on the opposite side of runway to the side with the defective tire to compensate for change in direction which is to be expected during final rolling.

Touchdown with the GOOD TIRE FIRST and hold aircraft with the flat tire off the ground as long as possible.

**5.4 Recovery from Unintentional Spin**

Power: ..... IDLE

Ailerons: ..... NEUTRAL (and Flaps Up)

Rudder: ..... FULL OPPOSITE

Elevator: ..... THROUGH NEUTRAL

**HOLD THESE INPUTS UNTIL ROTATION STOPS, THEN:**

Rudder: ..... NEUTRAL

Elevator: ..... RECOVER

**NOTE**

Use elevator control to recover to straight and level or a climbing attitude

**NOTE**

The first letter in each of the four primary recovery inputs spells out the acronym, PARE (pronounced “pair”). PARE is a convenient memory aid that points the way to spin recovery. The PARE format mimics the most docile spin configuration possible, affording the greatest response to recovery inputs. Errant control inputs that may aggravate the spin are avoided in the process. As a mental checklist, it forces you to focus on the appropriate recovery actions. Calling each item out loud also tends to reinforce the physical inputs.

**5.5 Other Emergencies****5.5.1 Unintentional Flight Into Icing Conditions**

Get away from icing conditions by changing altitude or direction of flight in order to reach an area with warmer external temperature.

Carburetor heat (optional): ..... ON

Increase rpm to avoid ice formation on propeller blades.

Cabin heat: ..... ON

**WARNING**

In case of ice formation on wing leading edge, stall speed may increase.

**5.5.2 Carburetor Ice****5.5.2.1 AT TAKEOFF**

At takeoff, carburetor heat (optional) is normally OFF given the unlikely possibility of ice formation at full throttle

**5.5.2.2 IN FLIGHT**

With external temperatures below 15° C, or on rainy days or with humid, cloudy, hazy or foggy conditions or whenever a power loss is detected, turn carburetor heat (optional) to ON until engine power is back to normal.

**5.6 Electric Power System Malfunction**

Electric power supply system malfunctions may be avoided by carrying out inspections as scheduled and prescribed in the Service Manual. Causes for malfunctions are hard to establish but, in any case, problems of this nature must be dealt with immediately. The following may occur:

**5.6.1 GENERATOR LIGHT ILLUMINATES**

Generator light may illuminate for a faulty alternator. If the generator light illuminates proceed as follows:

- LAND as soon as possible
- Continue flight on battery power alone; the battery is capable of supplying the electrical system for about 20 minutes with normal flight electric loads including operation of flap and trim.

**5.7 Trim System Failure****5.7.1 LOCKED CONTROL**

In case the trim control should not respond, act as follows:

Fuses / breakers ..... CHECK  
LH/RH switch ..... CHECK for correct position  
Airspeed ..... Adjust speed to control aircraft without excessive stick force  
Land aircraft as soon as possible

## SECTION 6 NORMAL PROCEDURES

### 6 Introduction

Section 6 contains checklists and the procedures for normal operation.

#### 6.1 Removing and Reinstalling the Engine Cowling

##### 6.1.1 Upper Cowling

Parking brake: .....ON or chocks installed

Fuel selector valves: .....OFF

Ignition Switches: .....OFF

Master switch: .....OFF

- Unlatch all four butterfly Cam-locks mounted on the top cowling by rotating them 90° counter clockwise while slightly pushing inwards.
- Remove the four screws holding the top canopy to the bottom.
- Remove top engine cowling paying attention to propeller shaft passing through nose.

*To reinstall:*

- Rest cowling horizontal insuring proper fitting of nose base reference pins. Reinstall the four screws.
- Secure latches by applying light pressure, check for proper assembly and fasten Cam-locks.

#### **WARNING**

Butterfly Cam-locks are locked when tabs are horizontal and open when tabs are vertical. Verify tab is below latch upon closing.

##### 6.1.2 Lower Cowling

*After disassembling upper cowling*

- Move the propeller to a horizontal position
- Using a standard screwdriver, press and rotate 90° the two Cam-locks positioned on lower cowling by the firewall.
- Disconnect the ram-air duct from the NACA intake. Pull out the first hinge pin positioned on the side of the firewall, then, while holding cowling, pull out second hinge pin; remove cowling with downward motion.

*For installation follow reverse procedure*

## 6.2 Checklist Procedures

### 6.2.1 Pre-Flight Inspection

Before each flight, it is necessary to carry out a complete inspection of the aircraft starting with an external inspection followed by an internal inspection.

#### 6.2.1.1 Cabin Inspection

All required paperwork: ..... ONBOARD  
Weight and balance: ..... CHECK  
Safety belts used to lock controls: ..... RELEASE  
Flight controls: ..... CHECK  
*Check for freedom of movement and proper direction*  
Parking brake: ..... SET  
Friction lock: ..... CHECK  
Throttle: ..... IDLE  
Ignition Switches: ..... OFF  
Master switch: ..... ON  
Generator light: ..... ON  
Aux. Alternator switch (if installed): ..... ON  
Alternator light: ..... ON  
Fuel pump: ..... ON  
*Check for audible sound and operation of fuel pressure indicator*  
Fuel pump: ..... OFF  
Flaps: ..... EXTEND  
*Visually check that flaps are fully extended and instrument indication is correct*  
Trim: ..... CHECK  
*Activate control in both directions checking for travel limits and instrument indication*  
Stall warning (optional): ..... CHECK  
Navigation lights and strobe-light (optional): ..... CHECK

#### NOTE

Strobe lights won't work without the engine running

Landing light (optional): ..... CHECK  
Fuel Tank levels: ..... CHECK  
Master switch: ..... OFF

#### WARNING

Fuel level indicated by the fuel quantity indicators (on the instrument panel) is only indicative. For flight safety, pilot should verify actual fuel quantity visually in tanks before takeoff.

**6.2.1.2 External Inspection**

To carry out the external inspection follow the checklist below following the order outlined in fig. 6-1.

Visual inspection is defined as follows: check for defects, cracks, detachments, excessive play, and unsafe or improper installation as well as for general condition. For control surfaces, visual inspection also involves additional check for freedom of movement and security.

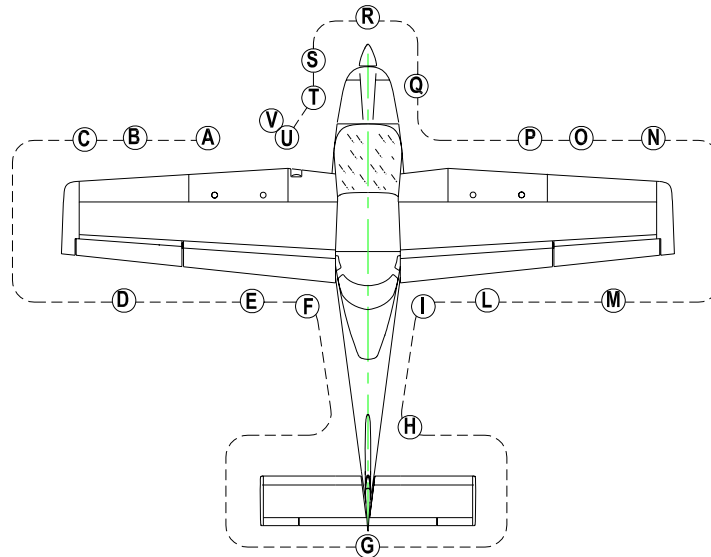

FIG. 6-1

- A. Left fuel filler cap: CHECK visually for desired fuel level and secure cap
- B. Pitot tube: Remove pitot tube cover and check that the pitot tube mounted on the left wing is unobstructed. Do not blow inside pitot tube.
- C. Left side leading edge and wing skin: CHECK for damage
- D. Left aileron: CHECK for damage, freedom of movement; Left tank vent: CHECK for obstructions
- E. Left flap and hinges: CHECK security
- F. Left main landing gear: CHECK inflation 23 psi (1.6 bar), tire condition, alignment, fuselage skin condition
- G. Horizontal tail and tab: CHECK for damage, freedom of movement
- H. Vertical tail and rudder: CHECK for damage, freedom of movement (note: do not move rudder unless nosewheel is lifted off the ground)
- I. Right side main landing gear: CHECK inflation 23 psi (1.6 bar), tire condition, alignment, fuselage skin condition
- L. Right flap and hinges: CHECK security
- M. Right aileron: CHECK for damage, freedom of movement; Right side tank vent: check for obstructions
- N. Right leading edge and wing skin: CHECK for damage
- O. Stall indicator micro switch (optional): Check freedom of movement, turn on Master switch and check cabin acoustic warning signal is operative, turn off Master switch
- P. Right side fuel filler cap: CHECK visually for desired fuel level and secure
- Q. Nose wheel strut and tire: CHECK inflation 15 psi (1.0 bar), tire condition and condition of rubber shock absorber discs.
- Q. Check the right static port for obstructions
- R. Propeller and spinner condition: CHECK for nicks and security
- S. Open both engine cowlings and perform the following checklist:
  - Check no foreign objects are present
  - Check the cooling circuit for losses, check coolant reservoir level, and insure radiator honeycomb is unobstructed
  - Check lubrication circuit for losses, check oil reservoir level, and insure radiator honeycomb is unobstructed

- Open both fuel shutoff valves and inspect fuel lines for leaks. Drain gascolator using a cup to collect fuel by opening the drain valve located on the firewall, close shutoff fuel valves. Check for water or other contaminants
- Engine mounts: CHECK integrity
- Intake system: CHECK connection and integrity of air intake system, visually inspect that ram air intake is unobstructed
- All parts: Check they are secured or safety wired

**WARNING**

Drain fuel with aircraft parked on level surface.

T. Close the engine cowlings: CHECK the left static port for obstructions

U. Landing Light (optional): CHECK

V. Tow bar and chocks: REMOVE

**6.2.1.3 BEFORE START**

Parking brake: ..... SET  
 Flight controls: ..... CHECK  
 Throttle: ..... IDLE  
 Friction lock: ..... ADJUST  
 Master switch: ..... ON  
 Generator light: ..... ON  
 Aux. Alternator switch (if installed): ..... ON  
 Aux. Alternator light (if installed): ..... ON  
 Trim control: ..... CENTERED  
 Trim switch: ..... LEFT  
 Landing light: ..... CHECK  
 Fuel quantity: ..... CHECK

**NOTE**

Compare the fuel levels read by the fuel quantity indicators with the quantity present in the tanks

Master switch: ..... OFF  
 Seat position and safety belts: ..... ADJUST  
*If flying solo:*  
 Passenger belts: ..... SECURED / CLEAR OF CONTROLS  
 Doors: ..... CLOSED AND LOCKED

**6.2.1.4 STARTING ENGINE**

Brakes: ..... SET  
 Fuel selector valves: ..... BOTH ON  
 Master switch: ..... ON  
 Throttle: ..... IDLE  
 Choke: ..... AS NEEDED  
 Propeller area: ..... CLEAR

**WARNING**

Check to insure no person or object is present in the area close to propeller

Strobe light: ..... ON  
 Ignition Switches: ..... ON  
 Master Switch: ..... START

**NOTE**

Activate starter for max of 10 seconds on followed by a cooling period of 2 minutes off before attempting a re-start

Oil pressure: ..... CHECK

**WARNING**

If oil pressure doesn't rise within 10 seconds, shut down engine.  
The maximum oil pressure for cold conditions is 7 bar.

Engine instruments: ..... CHECK  
Choke: ..... OFF  
Engine RPM: ..... 2000-2500 RPM  
Fuel pressure: ..... CHECK

**6.2.1.5 BEFORE TAXI**

Radio and Avionics (if installed): ..... ON  
Altimeter: ..... SET  
Flight Instruments: ..... SET, CHECK  
Parking brake: ..... OFF

**6.2.1.6 TAXI**

Brakes: ..... CHECK  
Flight instruments: ..... CHECK

**6.2.1.7 BEFORE TAKE-OFF**

Parking brake: ..... ON  
Engine instruments: ..... CHECK

- Oil temperature: ..... 50°-110 ° C
- Cylinder head temperature: ..... 90° - 135 °C
- Oil pressure: ..... 2 - 5 bar
- Fuel pressure: ..... 0.15 – 0.40 bar

Generator light: ..... OFF  
External Alternator light (if installed): ..... OFF  
Throttle: ..... 4000 RPM

*To test ignition systems:*

- Maximum RPM drop with only one ignition ..... 300 RPM
- Maximum differential between LEFT or RIGHT ..... 120 RPM

Carburetor Heat (optional): ..... CHECK  
Throttle: ..... IDLE  
Fuel quantity indicators: ..... CHECK  
Fuel selectors: ..... BOTH ON  
Flaps: ..... T/O (15°)  
Flight controls: ..... CHECK  
Trim: ..... CENTER  
Seat belts: ..... FASTENED  
Doors: ..... CLOSED AND LOCKED  
Transponder (if installed): ..... ALT

**6.2.1.8 TAKEOFF AND CLIMB**

Parking brake: ..... OFF  
Carburetor heat (optional): ..... OFF

*Taxi to line-up:*

Magnetic compass and DG (optional):..... CHECK, SET  
 Throttle:..... FULL

**NOTE**

Static RPM is approximately 5100 ± 250 rpm

Engine instruments:..... CHECK  
 Vr (Rotation speed):..... ~ 48 KIAS

**NOTE**

Rotate to takeoff attitude and accelerate to a climb speed of 60 knots with 15° Flaps

*Above 300' AGL:*

Flaps:..... RETRACT  
 Establish Vy clean:..... 68 KIAS  
 Trim:..... ADJUST  
 Cruise climb:..... 75 – 80 KNOTS

**6.2.1.9 CRUISE**

*Reaching cruise altitude:*

Throttle:..... SET (5500 RPM Max)  
 Engine instruments:..... CHECK

- Oil temperature: ..... 90°-110 ° C
- Cylinder head temperature: ..... 90° - 135 °C
- Oil pressure: ..... 2 - 5 bar
- Fuel pressure: ..... 0.15 – 0.40 bar

**CAUTION**

Normal position of the fuel selectors is both on. Check fuel balance and fuel pressure. If necessary, shut off the higher reading tank using the appropriate fuel shutoff valve. Check fuel pressure again. **BE SURE THAT ONE TANK IS FEEDING THE ENGINE AT ALL TIMES!**

**NOTE**

Check fuel gauges frequently with one tank shut off to prevent fuel starvation.

**6.2.1.10 BEFORE LANDING**

Landing light (if installed):..... ON  
*On downwind leg: Speed and flaps at your discretion based on traffic, etc.*  
 Traffic:..... CHECK  
 Flaps:..... AS DESIRED  
 Optimal touchdown speed (full flaps):..... 40 KNOTS

**6.2.1.11 BALKED LANDING**

Throttle:..... FULL  
 Airspeed: ..... 60 KIAS  
 Flaps position: ..... TO 15 degrees  
 Airspeed: ..... 65 KIAS  
 Trim:..... ADJUST  
*Above 300' AGL:*  
 Flaps:..... RETRACT  
 Establish Vy clean:..... 68 KIAS  
 Trim:..... ADJUST  
 After takeoff checklist:..... COMPLETE

**6.2.1.12 AFTER LANDING**

*Taxi at an appropriate speed for conditions*

Flaps:..... UP  
 Transponder: ..... STANDBY

**6.2.1.13 ENGINE SHUT DOWN**

Keep engine running at 2500 rpm for about one minute in order to reduce latent heat. This can be accomplished during taxi.

**NOTE**

Do not ride the brakes. If necessary stop for one minute with parking brake on to cool.

Electrical equipment (except the Strobe Light):..... OFF  
Ignition switches: ..... OFF  
Strobe light: ..... OFF  
Master switch: ..... OFF  
One or both fuel valves: ..... OFF  
Parking brake: ..... ON  
Chocks:..... INSTALL  
Parking brake: ..... OFF

**6.2.1.14 POSTFLIGHT CHECK**

Pitot tube cover: ..... INSTALL  
Aircraft: ..... TIED DOWN  
Control locks (if available):..... INSTALL  
Chocks:..... INSTALL  
Parking brake: ..... OFF  
Doors: ..... CLOSED AND LOCKED

## SECTION 7

# GROUND HANDLING & SERVICE

## 7 Introduction

This section contains factory-recommended procedures for proper ground handling and routine care and servicing. It also identifies certain inspection and maintenance requirements, which must be followed if the aircraft is to retain its new-plane performance and dependability. It is recommended to follow a planned schedule of lubrication and preventive maintenance based on climatic and flying conditions encountered locally.

### 7.1 Aircraft Inspection Periods

Inspection intervals occur at 100 hours and in accordance with special inspection schedules which are added to regularly scheduled inspections. Correct maintenance procedures are described in the aircraft's Service Manual or in the engine's Maintenance Manual.

### 7.2 Aircraft Alterations or Repairs

For repairs, refer to aircraft's Maintenance Manual.

### 7.3 Ground Handling

#### 7.3.1 Towing

The aircraft is most easily and safely maneuvered by pulling it by its propeller near the axle. Aircraft may be steered by turning rudder or, for steep turns, by pushing lightly on tailcone to lift nose wheel.

#### 7.3.2 Parking and Tie down

When parking airplane outdoors, head it into the wind and set the parking brake. If chocks or wedges are available it is preferable to use the latter.

In severe weather and high wind conditions it is wise to tie the airplane down. Tie-down ropes shall be fastened to the specific wings' attachments and anchoring shall be provided by ramp tie-downs. Nose gear fork can be used for front tie-down location.

Flight controls shall be secured to avoid possible weathervaning damage to moving surfaces. For this purpose, seatbelts may be used to latch control stick to prevent its movement.

#### 7.3.3 Jacking

Given the light empty weight of the aircraft, lifting one of the main wheels can easily be accomplished even without the use of hydraulic jacks. For an acceptable procedure please refer to the Maintenance Manual.

#### 7.3.4 Leveling

Aircraft leveling may become necessary to check wing incidence, dihedral or the exact location of CG. Longitudinal leveling verification is obtained placing a level longitudinally, over the aft part of the cabin floor (just in front of the seat).

#### 7.3.5 Road Transport

It is recommended to secure tightly all aircraft components onto the cart to avoid damage during transport. Minimum cart size is 7x2.5 meters. It is suggested to place wings under the aircraft's bottom, secured by specific clamps. Secondary

components such as stabilator and struts shall be protected from accidental hits using plastic or other material. For correct rigging and de-rigging procedure, refer to Maintenance Manual.

### **7.3.6 Cleaning and Care**

To clean painted surfaces, use a mild detergent such as shampoo normally used for car finish; use a soft cloth for drying.

The plastic windshield and windows should never be dusted when dry; use lukewarm soapy water and dry using chamois only. It is possible to use special glass detergents but, in any case, never use products such as gasoline, alcohol, acetone or other solvents.

To clean cabin interior, seats, upholstery and carpet, it is generally recommended to use foam-type detergents.

## Section 8

# REQUIRED PLACARDS & MARKINGS

### 8 Required Placards and Markings

The following limitation placards must be placed in plain view on the aircraft.  
Near the airspeed indicator a placard will state the following:

Maneuvering speed  $V_A = 96$  KIAS

On the right hand side of the panel a placard will state the following:

Passenger Warning  
This aircraft was manufactured in accordance with Light Sport  
aircraft airworthiness standards and does not conform to standard  
category airworthiness requirements.

On the pilot's panel a placard will state the following:

NO INTENTIONAL SPINS

Near baggage compartment a placard will state the following:

Fasten tie-down net  
Maximum weight 44 lbs

On the doors there are the following placards:

LIGHT SPORT

For other placards see the Maintenance Manual

## Section 9

# FLIGHT TRAINING SUPPLEMENT

## 9 Introduction

This Flight Training Supplement takes much of its information from the FAA's publication, Airplane Flying Handbook, FAA-H-8083-3a (AFH). There seems to be no reason to "reinvent the wheel." We encourage the pilot or student to obtain a copy and study the Airplane Flying Handbook. You can download the Airplane Flying Handbook from the Internet at <http://www.faa.gov/pilots/training/> for free or purchase a copy from your local bookstore.

We reference the Rotax Maintenance Manuals. You can download all of the Rotax manuals and bulletins from [www.rotax-owners.com](http://www.rotax-owners.com) site. We strongly encourage you to download the Rotax service manuals or use the CD that comes with your airplane and print them for your mechanic. Your mechanic will need the Rotax maintenance manuals to service your engine. Be sure the register your engine with Rotax at the same time so you will receive warranty information as well as current service bulletins.

This supplement is tailored to assist you in learning to fly and operate your new TECNAM airplane safely. Since this is a supplement, it is important that you read and study all of the documents and manuals that came with this aircraft as part of your training.

### 9.1.1 TECNAM History

The Company TECNAM srl was founded in 1986 by the brothers L. and G. Pascale whose names are associated with the design and manufacturing of famous light aircraft such as the PARTENAVIA single engine P64 and P66 OSCAR and the twin-engine P68 series. The TECNAM factory consists of two industrial plants: one is located near the International Airport in Naples and covers an area of about 12.000 sqm and the second is based beside of the Capua (CE) airport. As well as the P2002-JF and the other ULM & VLA programs, its production includes the ATR 42/72 stabilizer and elevators, the panel 56 of the B717 fuselage, component and assemblies of the Aermacchi SF260 as well as minor parts of other aircraft and helicopters. Each phase of the manufacturing process is in accordance with the requirements of the Airworthiness Authorities, thereby guarantees a high standard of workmanship. The industrial organization of the Company includes the Administration, Technical and Production Departments and a Quality Assurance Service.

### 9.1.2 Understanding ASTM Requirements

This airplane is an ASTM compliant airplane. Tecnam provides the FAA with a manufacturer's statement of compliance that states that this airplane is in compliance with the specifications of ASTM F 2245.

It is certificated under FAR part 21.190, Issue of a special airworthiness certificate for a light – sport category airplane. The FAA first published Order 8130.2F CHG 1 on April 1, 2005. This order and its subsequent revisions are what dictate how the airworthiness certificate is issued. You can download a copy of this order online free at [www.faa.org](http://www.faa.org).

Section 6 of Order 8130.2F CHG 1 defines the requirements of the issuance and continued airworthiness of light sport airworthiness certifications. It is important to understand that the FAA doesn't issue a type certificate for a light sport airplane. The manufacturer states the airplane complies with the ASTM compliance.

When everything is completed and the airworthiness certificate is issued, along with the airworthiness certificate, there are limitations that are assigned to this airplane. These limitations must be carried in the airplane at all times and must be complied with.

### 9.1.3 Aircraft Limitations

Your Tecnam airplane is certificated as a Special Light Sport category under part 21.190. In Order 8130.2F the following operating limitations are normally issued:

- No person may operate this aircraft for any other purpose than that for which the aircraft was certificated. This aircraft must be operated in accordance with applicable air traffic and general operating rules of part 91 and all additional limitations prescribed herein. These operating limitations are a part of Form 8 130-7 and are to be carried in the aircraft at all times and to be available to the pilot in command of the aircraft.
- The pilot in command of this aircraft must advise the passenger of the special nature of this aircraft and that the aircraft does not meet the certification requirements of a standard certificated aircraft.
- This aircraft must display the word "light-sport" in accordance with § 45.23(b).
- This aircraft must contain the placards and markings as required by § 91.9. In addition, the placards and markings must be inspected for legibility and clarity, and the associated systems inspected for easy access and operation, to ensure they function in accordance with the manufacturer's specifications during each condition inspection.
- Unless appropriately equipped for night and/or instrument flight in accordance with § 91.205, this aircraft is to be operated under VFR, day only.
- Noncompliance with these operating limitations will render the airworthiness certificate invalid. Any change, alteration, or repair not in accordance with the manufacturer's instruction and approval will render the airworthiness certificate invalid, and the owner of the aircraft must apply for a new airworthiness certificate under the provisions of § 21.191 with appropriate operating limitations before further flight.
- Application to amend these operating limitations must be made to the geographically responsible FSDO.
- This aircraft does not meet the requirements of the applicable, comprehensive, and detailed airworthiness code as provided by Annex 8 to the Convention on International Civil Aviation. The owner/operator of this aircraft must obtain written permission from another CAA before operating this aircraft in or over that country. That written permission must be carried aboard the aircraft together with the U.S. airworthiness certificate and, upon request, be made available to an ASI or the CAA in the country of operation.

It is important to understand these limitations and what they mean. For instance, number six states that "...Any change, alteration, or repair not in accordance with the manufacturer's instruction and approval will render the airworthiness certificate invalid". There are no STCs for this class of airplane since there is no FAA type certificate. Therefore, any alteration or change must either be approved in the maintenance manual supplied by Tecnam or you will need an authorization letter from Tecnam before you alter your airplane in any way. If this requirement is not complied with, then your airworthiness certificate is considered invalid and you are not legal to fly it until this has been rectified. Authorization to modify your airplane is not a difficult procedure. Just email us at [Tecnam@bellsouth.net](mailto:Tecnam@bellsouth.net) and we can get the authorization for you.

Just like any airplane that you fly, it is important to understand the rules that govern. The EAA has a wonderful document that summarizes the new rules. If you go to their website at [www.eaa.org](http://www.eaa.org) and check out the sport pilot page you will find many answers to your questions.

#### **9.1.4 Octane explained**

In most countries (including all of Europe and Australia) the "headline" octane that would be shown on the pump is the RON, but in the United States, Canada and some other countries the headline number is the average of the RON and the MON, sometimes called the Anti-Knock Index (AKI), Road Octane Number (Rd ON), Pump Octane Number (PON), or (R+M)/2. Because of the 8 to 10 point difference noted above, this means that the octane in the United States will be about 4 to 5 points lower than the same fuel elsewhere: 87 octane fuel, the "regular" gasoline in the US and Canada, would be 91-92 in Europe. However most European pumps deliver 95 (RON) as "regular", equivalent to 90-91 US (R+M)/2.

[http://en.wikipedia.org/wiki/Octane\\_rating](http://en.wikipedia.org/wiki/Octane_rating)

Rotax 912 ULS and S2 engines require US premium octane. Our premium using the AKI number of 91 is equivalent to RON 95 as specified in the Rotax manuals.

## 9.2 Preflight Planning

Part 14 CFR part 91 requires that before each flight, the pilot shall become familiar with all available information concerning the flight. Although you might be just doing a few touch and goes or taking mom for a \$100 hamburger, remember that for all flights the FAA regulations require that you are familiar with runway lengths, and take off and landing distances. See part 91.103 Preflight action.

If you are leaving the vicinity of the airport then the regulations require that you become familiar with:

- Weather reports and forecasts
- Fuel requirements
- Alternate and diversion plans
- Known traffic delays
- Aircraft performance

We recommend that you get a full briefing from the FSS. You can call them at 1-800-WX-BRIEF. September 11, 2001, has changed our world forever! It is important to make sure that there are no active TFRs along your route of flight.

Before each flight it is necessary to check weight and balance data for the flight, the required aircraft paperwork is in the aircraft, and visually inspect the airplane.

The certificates and documents that are required to be in the aircraft are:

- Airworthiness Certificate
- Registration Certificate
- Operating Limitations, required placards, and instrument markings
- Pilot Operating Handbook
- Flight Training Supplement
- Weight and Balance data

The maintenance manual is a required document but it is not required to be carried.

### 9.2.1 Checklists

Checklists have been the foundation of pilot standardization and cockpit safety for years. The checklist is an aid to the memory and helps to ensure that critical items necessary for the safe operation of aircraft are not overlooked or forgotten. However, checklists are of no value if the pilot is not committed to its use.

Without discipline and dedication to using the checklist at the appropriate times, the odds are on the side of error. Pilots who fail to take the checklist seriously become complacent and the only thing they can rely on is memory.

The importance of consistent use of checklists cannot be overstated in pilot training. A major objective in primary flight training is to establish habit patterns that will serve pilots well throughout their entire flying career. The flight instructor must promote a positive attitude toward the use of checklists, and the student pilot must realize its importance. At a minimum, prepared checklists should be used for the following phases of flight. AFM

Preflight Inspection	Cruise
Before Engine Start	Descent
Starting Engine	Before Landing
Before Taxiing	Balked Landing
Taxiing	After Landing
Before Takeoff	Engine Shutdown and Securing
After Takeoff	Postflight Check

### 9.2.2 IM SAFE

Before entering the airplane, the pilot needs to do a self-assessment “checklist”. The acronym IM SAFE is a good way to accomplish this.

I      Illness  
M      Medications  
S      Stress  
A      Alcohol  
F      Fatigue  
E      Eating

Once you have determined that you, the pilot, is safe to fly, it is time to make sure your airplane is safe and legal as well.

### 9.2.3 Preflight Inspection

The preflight inspection of the airplane is broken down into the cabin inspection and the exterior inspection. Normal Procedures are located in Chapter 7 of the POH. This should be reviewed.

### 9.2.4 Cabin Inspection

Make sure that the cabin floor is clean, there is nothing that could affect the control movements, and the general condition of the interior is acceptable. This is in addition to the normal items on the checklist.

### 9.2.5 External Inspection

Make sure that the parking brake is set or the airplane is chocked before doing the external inspection.

Follow the same procedures each time so there is less chance of forgetting something. The idea of an external inspection is not to become a mechanic but to find discrepancies that should be obvious. Leaks, broken parts, safety wire, etc are areas that you are looking for.

Make sure that when you are looking in the engine compartment and on the belly of the airplane that there are no suspicious leaks. Don't forget to check the fluid levels and the exhaust springs. There are four springs on each side.

### 9.2.6 Before Start

Make sure that the parking brake is set and the area is clear. It is important to follow the checklist items as a checklist and not a do list. Be sure to check oil pressure right away and respect the duty cycle of the starter motor.

### 9.2.7 Engine Start

When ready to start the engine, the pilot should look in all directions to be sure that nothing is or will be in the vicinity of the propeller. This includes nearby persons and aircraft that could be struck by the propeller blast or the debris it might pick up from the ground. The anti-collision light should be turned on prior to engine start, even during daytime operations. At night, the position (navigation) lights should also be on. The pilot should always call “CLEAR” out of the side window and wait for a response from persons who may be nearby before activating the starter. AFH

Since there are no toe brakes installed, make sure that the parking brake is set before starting the engine.

Starting the Rotax engine is easy if you follow the checklist and a few simple guidelines.

The Rotax engine has a dry sump forced lubrication system. This means that the oil is stored in an oil tank and not on the bottom of the engine. If you haven't started the engine yet today or it is very cold, then it is good practice to turn the engine over with the ignition switches off. Turn the ignition switches on to start the engine when you see oil pressure indicated on the gauge.

If you are starting the engine in cold conditions, then you may have to use the choke. If you are using the choke, the throttle has to be all the way out otherwise the choke won't work.

Respect the starter duty cycle of 10 seconds on followed by 2 minutes of cooling.

Be sure to look around before you start the engine. Make sure that the propeller area is clear. Before hitting that starter switch, yell “clear”. Look around. Oh, and did I say, make sure the parking brake is set?

Once the engine is started, make sure that all of the engine parameters are in the green before you move the airplane. Warm the engine up at low idle speeds. There is enough to do while taxiing!

### **9.2.8 Before Taxiing**

Do as much as you can while parked so you are not distracted while taxiing. Make sure the radios are on, instruments are checked and set and whatever lights are needed are on before you release the brakes.

Have a taxi plan in your mind before releasing the brakes. If you are at an unfamiliar airport, then make sure that you have a taxi diagram available. Review this diagram before calling ground control or taxiing out.

### **9.2.9 Taxiing**

This airplane has direct steering to the nosewheel. So, you do not want to press on the rudder pedals when you are stopped. This will put unnecessary pressure on the linkage. Make sure the propeller RPM is low before releasing the parking brake so the airplane won't lunge forward. Use the left hand throttle while taxiing. This allows you to use your right hand on the brake handle. Make sure that you are controlling taxi speed with the throttle and not just the brakes. Pull the power back so you are not riding the brakes as you taxi. This will extend the life of the brake linings and give you better control of the airplane.

### **9.2.10 Before Takeoff Checks**

Make sure the parking brake is on and you are not going to blast anyone or anything while you check your engine. Turn the airplane into the wind. This is better for cooling and stability and becomes increasingly more important as the winds increase in intensity.

Be sure that the ground below you is clear of debris so you do not damage the propeller. Don't get lost inside the airplane! Be sure to look out the window so you are certain that the parking brake is holding.

Before taking the active runway have a takeoff plan. Have you reviewed the emergency procedures? Do you know what heading, altitude, and airspeed you need? How about direction of flight? Reviewing these types of things on the ground will make the flight safer and more enjoyable.

### **9.2.11 Takeoff and Climb**

Do you have a crosswind? Make sure that you apply the correct aileron correction for the current wind conditions. Maintain the wings level with the ailerons and the airplane on the runway centerline with the rudders. As you reach rotation speed, lift the nose to the takeoff attitude. When the nosewheel comes off the ground you will have to use more right rudder to stay straight. Maintain this attitude in the climb until reaching about 300' AGL. Then you can raise the flaps and lower the nose to a climb attitude. Remember to adjust your climb attitude first, and then check the airspeed indicator to confirm that you are at the correct airspeed. Do not chase the airspeed indicator. Remember that the airplane takes time to accelerate and decelerate. If you maintain a constant pitch attitude, check the airspeed, and then fine tune the attitude, you will get much better performance from the airplane and your passenger will be much happier!

Is the ball in the center and you wings level? Remember that the rudders are used to keep the airplane coordinated. They are not just for ground operations. You will find that the flight will be more comfortable and more efficient if you keep the airplane coordinated. If the airplane is slipping or skidding, then you are adding drag.

### **9.2.12 Cruise**

Once level, you adjust the power for cruise. Maintain fuel balance by shutting off the fuel selector for the lower tank.

Whenever you move a fuel lever, switch on the electric fuel pump and watch your fuel pressure. Once assured that all is well then you can turn off the fuel pump. The airplane should be trimmed for hands off. Light control pressures are usually all that is needed to keep the airplane straight and level. There is no need to lean the engine since it is automatic.

### **9.2.13 Descent**

Plan your descent so you do not have to pull the power all the way off. You don't want to shock cool the engine especially in cold weather.

Check your engine instruments and your fuel balance. Try to get everything done that you can before you get within five miles of your destination airport. Remember that this airplane has a glide ratio of approximately 10:1. Start early! Are you ready to land? Let's go.

**9.2.14 Before Landing**

It is important to be aware of the correct pitch attitudes as you transition from cruise to slow flight. As you get more proficient with the airplane, you will be able to anticipate the correct pitch attitude quickly refining it for present conditions. Since the approach speed is slower than you might be used to, it becomes even more important to coordinate with the rudders. On final approach it is a good time to determine how much crosswind you have. It is good procedure that as you descend below approximately 200' AGL that you switch from a crab to a forward slip so that the longitudinal axis is parallel to the centerline of the runway throughout the landing and rollout.

**9.2.15 Balked Landing**

Attitude control is vital for a successful balked landing. There will be a tendency for the nose to rise since the trim was set for landing. Fly the airplane first, and then proceed with checklist items.

**9.2.16 Landing**

There is one rule for all tricycle gear airplanes - Land on the main wheels first! There is never a reason to land three point or on the nosewheel! You have a lot of pitch control throughout the landing roll even at slow speeds. Remember, the idea is to land in a landing pitch attitude.

In a crosswind, the upwind main wheel touches first, then the other main gear, and then the nosewheel. It is important to keep in mind, that in any airplane, not just this one, that you continue to correct for the crosswind with increasing amounts of aileron deflection and maintain directional control with rudder.

**9.2.17 After Landing**

Be sure to turn off the runway before activating any switches or doing the after landing checklist. It is better to slow down before turning off and not in the turn. This will prevent any possibility of putting excessive sidewise pressure on the landing gear. Do not taxi while performing the after landing checklist. It is best to stop. Remember, you are still "flying" until the aircraft is shut down and chocked.

**9.2.18 Engine Shutdown and Securing**

Cooling the engine is important and can be done on the taxi in. Make sure that you set the parking brake while you go through your shut down checklist.

**9.2.19 Post Flight Check**

It takes about a minute or two to cool the engine. Be sure to turn off all radios first before shutting down the engine. The engine shuts down immediately when the ignition switches are turned off. Be sure that the parking brake is set or the airplane is chocked. Once chocked, be sure to release the brakes.

## 9.3 Flight Maneuvers

There are four fundamental basic flight maneuvers upon which all flying tasks are based: straight-and level flight, turns, climbs, and descents. All controlled flight consists of either one, or a combination or more than one, of these basic maneuvers. If a student pilot is able to perform these maneuvers well, and the student's proficiency is based on accurate "feel" and control analysis rather than mechanical movements, the ability to perform any assigned maneuver will only be a matter of obtaining a clear visual and mental conception of it. The flight instructor must impart a good knowledge of these basic elements to the student, and must combine them and plan their practice so that perfect performance of each is instinctive without conscious effort. The importance of this to the success of flight training cannot be overemphasized. As the student progresses to more complex maneuvers, discounting any difficulties in visualizing the maneuvers, most student difficulties will be caused by a lack of training, practice, or understanding of the principles of one or more of these fundamentals. AFH

### 9.3.1 Straight and Level Flight

It is impossible to emphasize too strongly the necessity for forming correct habits in flying straight and level. All other flight maneuvers are in essence a deviation from this fundamental flight maneuver. Many flight instructors and students are prone to believe that perfection in straight-and-level flight will come of itself, but such is not the case. It is not uncommon to find a pilot whose basic flying ability consistently falls just short of minimum expected standards, and upon analyzing the reasons for the shortcomings to discover that the cause is the inability to fly straight and level properly.

The pitch attitude for level flight (constant altitude) is usually obtained by selecting some portion of the airplane's nose as a reference point, and then keeping that point in a fixed position relative to the horizon. Using the principles of attitude flying, that position should be cross-checked occasionally against the altimeter to determine whether or not the pitch attitude is correct. If altitude is being gained or lost, the pitch attitude should be readjusted in relation to the horizon and then the altimeter rechecked to determine if altitude is now being maintained. AFH

### 9.3.2 Turns

The ailerons bank the wings and so determine the rate of turn at any given airspeed. The elevator moves the nose of the airplane up or down in relation to the pilot, and perpendicular to the wings. Doing that, it both sets the pitch attitude in the turn and "pulls" the nose of the airplane around the turn. The throttle provides thrust, which may be used for airspeed to tighten the turn. The rudder offsets any yaw effects developed by the other controls. AFH

In all constant altitude, constant airspeed turns, it is necessary to increase the angle of attack of the wing when rolling into the turn by applying up elevator. This is required because part of the vertical lift has been diverted to horizontal lift. Thus, the total lift must be increased to compensate for this loss. To stop the turn, the wings are returned to level flight by the coordinated use of the ailerons and rudder applied in the opposite direction. AFH

Excellent coordination and timing of all the controls in turning requires much practice. It is essential that this coordination be developed, because it is the very basis of this fundamental flight maneuver. AFH

### 9.3.3 Climbs

When an airplane enters a climb, it changes its flight-path from level flight to an inclined plane or climb attitude. In a climb, weight no longer acts in a direction perpendicular to the flight path. It acts in a rearward direction. This causes an increase in total drag requiring an increase in thrust (power) to balance the forces. An airplane can only sustain a climb angle when there is sufficient thrust to offset increased drag; therefore, climb is limited by the thrust available. Like other maneuvers, climbs should be performed using outside visual references and flight instruments. It is important that the pilot know the engine power settings and pitch attitudes that will produce the following conditions of climb.

**NORMAL CLIMB**—Normal climb is performed at an airspeed recommended by the airplane manufacturer. Normal climb speed is generally somewhat higher than the airplane's best rate of climb. The additional airspeed provides better engine cooling, easier control, and better visibility over the nose. Normal climb is sometimes referred to as "cruise climb."

**BEST RATE OF CLIMB**—Best rate of climb ( $V_Y$ ) is performed at an airspeed where the most excess power is available over that required for level flight. This condition of climb will produce the most gain in altitude in the least amount of time (maximum rate of climb in feet per minute). The best rate of climb made at full allowable power is a maximum climb. It must be fully understood that attempts to obtain more climb performance than the airplane is capable of by increasing pitch attitude will result in a decrease in the rate of altitude gain.

**BEST ANGLE OF CLIMB**—Best angle of climb ( $V_X$ ) is performed at an airspeed that will produce the most altitude gain in a given distance. Best angle-of climb airspeed ( $V_X$ ) is considerably lower than best rate of climb ( $V_Y$ ), and is the airspeed where the most excess thrust is available over that required for level flight. The best angle of climb will result in a steeper climb path, although the airplane will take longer to reach the same altitude than it would at best rate of climb. The best angle of climb, therefore, is used in clearing obstacles after takeoff.

It should be noted that, as altitude increases, the speed for best angle of climb increases, and the speed for best rate of climb decreases. The point at which these two speeds meet is the absolute ceiling of the airplane.

A straight climb is entered by gently increasing pitch attitude to a predetermined level using back-elevator pressure, and simultaneously increasing engine power to the climb power setting. Due to an increase in downwash over the horizontal stabilizer as power is applied, the airplane's nose will tend to immediately begin to rise of its own accord to an attitude higher than that at which it would stabilize. The pilot must be prepared for this. As a climb is started, the airspeed will gradually diminish. This reduction in airspeed is gradual because of the initial momentum of the airplane. The thrust required to maintain straight-and-level flight at a given airspeed is not sufficient to maintain the same airspeed in a climb. Climbing flight requires more power than flying level because of the increased drag caused by gravity acting rearward. Therefore, power must be advanced to a higher power setting to offset the increased drag. The propeller effects at climb power are a primary factor. This is because airspeed is significantly slower than at cruising speed, and the airplane's angle of attack is significantly greater. Under these conditions, torque and asymmetrical loading of the propeller will cause the airplane to roll and yaw to the left. To counteract this, the right rudder must be used. AFH

### 9.3.4 Descents

To enter a glide, the pilot should close the throttle. A constant altitude should be held with backpressure on the elevator control until the airspeed decreases to the recommended glide speed. Due to a decrease in downwash over the horizontal stabilizer as power is reduced, the airplane's nose will tend to immediately begin to lower of its own accord to an attitude lower than that at which it would stabilize. The pilot must be prepared for this. To keep pitch attitude constant after a power change, the pilot must counteract the immediate trim change. If the pitch attitude is allowed to decrease during glide entry, excess speed will be carried into the glide and retard the attainment of the correct glide angle and airspeed. Speed should be allowed to dissipate before the pitch attitude is decreased. This point is particularly important in so-called clean airplanes as they are very slow to lose their speed and any slight deviation of the nose downwards results in an immediate increase in airspeed. Once the airspeed has dissipated to normal or best glide speed, the pitch attitude should be allowed to decrease to maintain that speed. This should be done with reference to the horizon. When the speed has stabilized, the airplane should be re-trimmed for "hands off" flight. When the approximate gliding pitch attitude is established, the airspeed indicator should be checked. If the airspeed is higher than the recommended speed, the pitch attitude is too low, and if the airspeed is less than recommended, the pitch attitude is too high; therefore, the pitch attitude should be readjusted accordingly referencing the horizon. After the adjustment has been made, the airplane should be re-trimmed so that it will maintain this attitude without the need to hold pressure on the elevator control. The principles of attitude flying require that the proper flight attitude be established using outside visual references first, then using the flight instruments as a secondary check. It is a good practice to always re-trim the airplane after each pitch adjustment.

A stabilized power-off descent at the best glide speed is often referred to as a normal glide. The flight instructor should demonstrate a normal glide, and direct the student pilot to memorize the airplane's angle and speed by visually checking the airplane's attitude with reference to the horizon, and noting the pitch of the sound made by the air passing over the structure, the pressure on the controls, and the feel of the airplane. Due to lack of experience, the beginning student may be unable to recognize slight variations of speed and angle of bank immediately by vision or by the pressure required on the controls. Hearing will probably be the indicator that will be the most easily used at first. The instructor should, therefore, be certain that the student understands that an increase in the pitch of sound denotes increasing speed, while a decrease in pitch denotes less speed. When such an indication is received, the student should consciously apply the other two means of perception so as to establish the proper relationship. The student pilot must use all three elements consciously until they become habits, and must be alert when attention is diverted from the attitude of the airplane and be responsive to any warning given by a variation in the feel of the airplane or controls, or by a change in the pitch of the sound. After a good comprehension of the normal glide is attained, the student pilot should be instructed in the differences in the results of normal and "abnormal" glides. Abnormal glides being those conducted at speeds other than the normal best glide speed. Pilots who do not acquire an understanding and appreciation of these differences will experience difficulties with accuracy landings, which are comparatively simple if the fundamentals of the glide are thoroughly understood. Too fast a glide

during the approach for landing invariably results in floating over the ground for varying distances, or even overshooting, while too slow a glide causes undershooting, flat approaches, and hard touchdowns. A pilot without the ability to recognize a normal glide will not be able to judge where the airplane will go, or can be made to go, in an emergency. Whereas, in a normal glide, the flight-path may be sighted to the spot on the ground on which the airplane will land. This cannot be done in any abnormal glide. AFH

### **9.3.5 Stalls**

14 CFR part 61 requires that a student pilot receive and log flight training in stalls and stall recoveries prior to solo flight. During this training, the flight instructor should emphasize that the direct cause of every stall is an excessive angle of attack. The student pilot should fully understand that there are a number of flight maneuvers which may produce an increase in the wing's angle of attack, but the stall does not occur until the angle of attack becomes excessive. This "critical" angle of attack varies from 16 to 20° depending on the airplane design.

The flight instructor must emphasize that low speed is not necessary to produce a stall. The wing can be brought to an excessive angle of attack at any speed. High pitch attitude is not an absolute indication of proximity to a stall. Some airplanes are capable of vertical flight with a corresponding low angle of attack. Most airplanes are quite capable of stalling at a level or near level pitch attitude.

The key to stall awareness is the pilot's ability to visualize the wing's angle of attack in any particular circumstance, and thereby be able to estimate his/her margin of safety above stall. This is a learned skill that must be acquired early in flight training and carried through the pilot's entire flying career. The pilot must understand and appreciate factors such as airspeed, pitch attitude, load factor, relative wind, power setting, and aircraft configuration in order to develop a reasonably accurate mental picture of the wing's angle of attack at any particular time. It is essential to flight safety that a pilot takes into consideration this visualization of the wing's angle of attack prior to entering any flight maneuver. AFH

These aircraft have normal stall characteristics. There are no surprises. You will get ample warning and, if coordinated, the airplane has little tendency to break to the left or right. There is little need to "push" the stick forward. Releasing the backpressure to reduce the angle of attack will get the airplane flying again. Prompt application of power will minimize altitude loss.

Remember, recovery from a stall is accomplished by reducing the angle of attack. Power is used to minimize altitude lost.

### **9.3.6 Slow Flight**

Slow flight could be thought of, by some, as a speed that is less than cruise. In pilot training and testing, however, slow flight is broken down into two distinct elements: (1) the establishment, maintenance of, and maneuvering of the airplane at airspeeds and in configurations appropriate to takeoffs, climbs, descents, landing approaches and go-arounds, and, (2) maneuvering at the slowest airspeed at which the airplane is capable of maintaining controlled flight without indications of a stall—usually 3 to 5 knots above stalling speed. AFH

Maneuvering during slow flight demonstrates the flight characteristics and degree of controllability of an airplane at less than cruise speeds. The ability to determine the characteristic control responses at the lower airspeeds appropriate to takeoffs, departures, and landing approaches is a critical factor in stall awareness.

As airspeed decreases, control effectiveness decreases disproportionately. For instance, there may be a certain loss of effectiveness when the airspeed is reduced from 30 to 20 M.P.H. above the stalling speed, but there will normally be a much greater loss as the airspeed is further reduced to 10 M.P.H. above stalling. The objective of maneuvering during slow flight is to develop the pilot's sense of feel and ability to use the controls correctly, and to improve proficiency in performing maneuvers that require slow airspeeds.

Maneuvering during slow flight should be performed using both instrument indications and outside visual reference. Slow flight should be practiced from straight glides, straight-and-level flight, and from medium banked gliding and level flight turns. Slow flight at approach speeds should include slowing the airplane smoothly and promptly from cruising to approach speeds without changes in altitude or heading, and determining and using appropriate power and trim settings. Slow flight at approach speed should also include configuration changes, such as landing gear and flaps, while maintaining heading and altitude. AFH

### 9.3.7 Flight at minimum controllable airspeed

This maneuver demonstrates the flight characteristics and degree of controllability of the airplane at its minimum flying speed. By definition, the term “flight at minimum controllable airspeed” means a speed at which any further increase in angle of attack or load factor, or reduction in power will cause an immediate stall. Instruction in flight at minimum controllable airspeed should be introduced at reduced power settings, with the airspeed sufficiently above the stall to permit maneuvering, but close enough to the stall to sense the characteristics of flight at very low airspeed—which are sloppy controls, ragged response to control inputs, and difficulty maintaining altitude. Maneuvering at minimum controllable airspeed should be performed using both instrument indications and outside visual reference. It is important that pilots form the habit of frequent reference to the flight instruments, especially the airspeed indicator, while flying at very low airspeeds. However, a “feel” for the airplane at very low airspeeds must be developed to avoid inadvertent stalls and to operate the airplane with precision.

To begin the maneuver, the throttle is gradually reduced from cruising position. While the airspeed is decreasing, the position of the nose in relation to the horizon should be noted and should be raised as necessary to maintain altitude.

When the airspeed reaches the maximum allowable for landing gear operation, the landing gear (if equipped with retractable gear) should be extended and all gear down checks performed. As the airspeed reaches the maximum allowable for flap operation, full flaps should be lowered and the pitch attitude adjusted to maintain altitude. Additional power will be required as the speed further decreases to maintain the airspeed just above a stall. As the speed decreases further, the pilot should note the feel of the flight controls, especially the elevator. The pilot should also note the sound of the airflow as it falls off in tone level.

As airspeed is reduced, the flight controls become less effective and the normal nose down tendency is reduced. The elevators become less responsive and coarse control movements become necessary to retain control of the airplane. The slipstream effect produces a strong yaw so the application of rudder is required to maintain coordinated flight. The secondary effect of applied rudder is to induce a roll, so aileron is required to keep the wings level. This can result in flying with crossed controls. During these changing flight conditions, it is important to retrim the airplane as often as necessary to compensate for changes in control pressures. If the airplane has been trimmed for cruising speed, heavy aft control pressure will be needed on the elevators, making precise control impossible. If too much speed is lost, or too little power is used, further backpressure on the elevator control may result in a loss of altitude or a stall. When the desired pitch attitude and minimum control airspeed have been established, it is important to continually cross-check the attitude indicator, altimeter, and airspeed indicator, as well as outside references to ensure that accurate control is being maintained.

The pilot should understand that when flying more slowly than minimum drag speed (LD/MAX) the airplane will exhibit a characteristic known as “speed instability.” If the airplane is disturbed by even the slightest turbulence, the airspeed will decrease. As airspeed decreases, the total drag also increases resulting in a further loss in airspeed. The total drag continues to rise and the speed continues to fall. Unless more power is applied and/or the nose is lowered, the speed will continue to decay right down to the stall. This is an extremely important factor in the performance of slow flight. The pilot must understand that, at speed less than minimum drag speed, the airspeed is unstable and will continue to decay if allowed to do so.

When the attitude, airspeed, and power have been stabilized in straight flight, turns should be practiced to determine the airplane’s controllability characteristics at this minimum speed. During the turns, power and pitch attitude may need to be increased to maintain the airspeed and altitude. The objective is to acquaint the pilot with the lack of maneuverability at minimum speeds, the danger of incipient stalls, and the tendency of the airplane to stall as the bank is increased. A stall may also occur as a result of abrupt or rough control movements when flying at this critical airspeed.

Abruptly raising the flaps while at minimum controllable airspeed will result in lift suddenly being lost, causing the airplane to lose altitude or perhaps stall.

Once flight at minimum controllable airspeed is set up properly for level flight, a descent or climb at minimum controllable airspeed can be established by adjusting the power as necessary to establish the desired rate of descent or climb. The beginning pilot should note the increased yawing tendency at minimum control airspeed at high power settings with flaps fully extended. In some airplanes, an attempt to climb at such a slow airspeed may result in a loss of altitude, even with maximum power applied.

As airspeed is reduced, the flight controls become less effective and the normal nose down tendency is reduced. The elevators become less responsive and coarse control movements become necessary to retain control of the airplane. The slipstream effect produces a strong yaw so the application of rudder is required to maintain coordinated flight. The secondary effect of applied rudder is to induce a roll, so aileron is required to keep the wings level. This can result in flying with crossed controls.

During these changing flight conditions, it is important to re-trim the airplane as often as necessary to compensate for changes in control pressures. If the airplane has been trimmed for cruising speed, heavy aft control pressure will be needed on the elevators, making precise control impossible. If too much speed is lost, or too little power is used, further back pressure on the elevator control may result in a loss of altitude or a stall. When the desired pitch attitude and minimum control airspeed have been established, it is important to continually cross-check the attitude indicator, altimeter, and airspeed indicator, as well as outside references to ensure that accurate control is being maintained.

When the attitude, airspeed, and power have been stabilized in straight flight, turns should be practiced to determine the airplane's controllability characteristics at this minimum speed. During the turns, power and pitch attitude may need to be increased to maintain the airspeed and altitude. The objective is to acquaint the pilot with the lack of maneuverability at minimum speeds, the danger of incipient stalls, and the tendency of the airplane to stall as the bank is increased. A stall may also occur as a result of abrupt or rough control movements when flying at this critical airspeed.

Abruptly raising the flaps while at minimum controllable airspeed will result in lift suddenly being lost, causing the airplane to lose altitude or perhaps stall.

Once flight at minimum controllable airspeed is set up properly for level flight, a descent or climb at minimum controllable airspeed can be established by adjusting the power as necessary to establish the desired rate of descent or climb. The beginning pilot should note the increased yawing tendency at minimum control airspeed at high power settings with flaps fully extended. In some airplanes, an attempt to climb at such a slow airspeed may result in a loss of altitude, even with maximum power applied. This aircraft has solid low speed handling characteristics. It is important to remember to stay coordinated. Remember, the more movement of one flight control requires more movement of the other controls. For instance, the more aileron needed, the more adverse aileron drag, therefore the more rudder needed to stay coordinated. AFH

## **9.4 Performance Maneuver**

### **9.4.1 Steep Turns**

Steep turns are those resulting from a degree of bank (45° or more) at which the "over banking tendency" of an airplane overcomes stability, and the bank increases unless aileron is applied to prevent it. AFH

The visibility in this airplane is very good. This is a VFR maneuver! You will have greater success if you spend most of you time looking outside the aircraft checking the altimeter and the airspeed indicator as a check that you are holding the right amount of pitch. If you begin to descent, reduce the angle of bank first, then raise your pitch attitude then resume you steep bank.

## **9.5 Emergency Procedures**

The emergency procedures are covered in the Aircraft Operating Instructions so they don't need to be gone over in this manual. Do remember that the airplane's systems are basic by design. Memorize the checklists in the POH. Preparation and practice will assist you in any emergency.

If you practice coordination and make it a regular habit there is little chance of entering into a spin. If, in the unlikely event, that you do enter a spin remember Throttle, Rudder, Stick! Reduce the throttle to idle, then check the direction of rotation and apply opposite rudder until rotation stops. Relax the control stick and rudder and recover from the stall. Smoothly apply back stick pressure and pull out of the dive without exceeding redline airspeed.

Engine failures are very rare but they do occur. Anytime that you are flying you should be looking at available landing sites while enjoying the beautiful scenery. There is no reason to land anywhere else than on a runway while in the traffic pattern except on climb out where you may have to land straight ahead. Plan your traffic pattern so that no matter where you are, you can still make it to the runway and land safely. Don't fall prey to the common error of being low and slow with lots of drag on final.

Feedback Form



Send your comments to:



In the USA:

Tecnam Aircraft, Inc.  
1350 Churchill Way  
Marietta, GA 30062  
[www.tecnamaircraft.com](http://www.tecnamaircraft.com)  
Tecnam@bellsouth.net  
(770) 309-4155

Italian Address:

COSTRUZIONI AERONAUTICHE TECNAM s.r.l.  [www.tecnam.com](http://www.tecnam.com)

Casoria industrial plant  
1a Traversa via G. Pascoli n°1  
80026 Casoria (NA) – ITALY  
 +39 081 7583210  +39 081 7584528

Capua industrial plant  
Via Maiorise  
81043 Capua (CE) - ITALY  
 +39 0823 620134  +39 0823 622899